



STE35SR
Crawler-type Hydraulic Excavator
Operation & Maintenance
Manual

CFG INDUSTRIAL Ltd.

© All rights reserved by CFG INDUSTRIAL Ltd.

FOREWORD

Version: V1.0 2023.1
No. : 60025-01-00005

Foreword

The *Operator's Manual* is used for safety guidelines and the correct use and maintenance of the machine. The operation and maintenance steps described are the most effective methods for operation and maintenance. Following these instructions helps to ensure the effectiveness, economy and reliability of equipment maintenance. Careful reading of the relevant contents of "**NOTICE**" and "**WARNING**" in the driver's manual will minimize the risk of casualties and machine damage or unsafe factors caused by improper maintenance.

WARNING

- Before starting and operating the machine for the first time, and before repairing the machine, you should read the instructions carefully and understand thoroughly.
- Read the safety messages and safety labels given in this manual carefully so that they should be understood fully.
- This manual should always be placed next to the machine for easy reference, if the manual is lost, damaged or illegible should be replaced (immediately request a new manual to CFG INDUSTRIAL Ltd. or your CFG distributor to obtain a new copy.
- When you sell the machine, make sure that this manual should be provided to the new owner together with the machine.

NOTICE



- This manual is applicable to STE35SR.
- This manual has been adapted to all markets. Optional and special equipment from different markets should be ignored because they may not be suitable for your machine.
- We reserve the right to modify and improve technical data, specifications, design, operation and maintenance instructions of the product without prior notice.
- Due to the unpredictable operation and maintenance of various conditions that may contain potential hazards. Therefore, this manual and the safety information on the machine will not include all possible safety measures. If you use methods or actions not specifically recommended or permitted in this manual, you are responsible for taking necessary measures to ensure safety.
- Unauthorized modification or abuse of the machine may affect the performance of the excavator or cause greater safety risks. Please drive and use the machine with caution. Disoperation and misuse may also cause damage.

Application range of standard machine: altitude below 2000m, atmospheric temperature -20°C ~40°C.

The location of the Operator's Manual

Storage location for the Operator's Manual: magazine box on the back of operator's seat.

In addition to this manual, please refer to the instruction manual of the engine for details on the use, maintenance, and troubleshooting of the engine.

In the book where the requirements for the safety of people, machine and important technology in place, all have symbol prompts  and , please bear in mind.

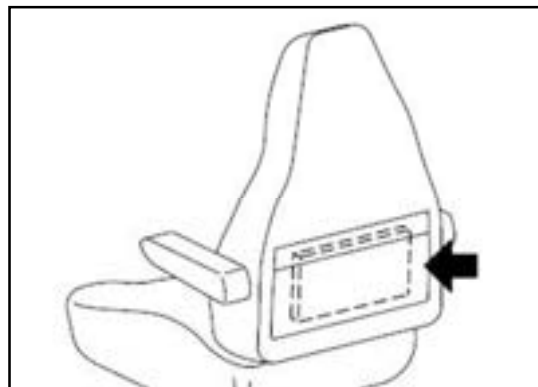

Safety Regulations

To operate and use the machine, you must follow the rules and regulations issued by national, provincial, autonomous region, and government. Therefore, the operating instructions and safety information contained in this manual are merely some helpful advice.

The following symbols together with texts mean the following as they appear in this manual:



- Warning, keep alert! It concerns your own safety!
- Ignorance of such risk may result in accident, serious injury even death.
- It's the operator's liability to ensure that all warning signs are kept on the machine in good condition and legibly. Otherwise accident is most likely to occur.
- Familiarize with the functions and limitations of the machine.

In addition to the above, the following signal words are used to indicate precautions that should be followed to protect the machine or to give information that is useful to know.

NOTICE This word Indicates that when the wrong operation is carried out, it may cause damage to the machine or shorten the service life of the machine.

REMARKS This word is used for information that is useful to know.

Vehicle Operation and Maintenance

CFG industrial ltd. will provide warranty services only in the following cases:

- The machine is used and maintained according to this manual.
- Service and maintenance of components are handled with the time.
- Lubricants and fuel are used according to this manual.
- None of protection seals installed is damaged or some protection seals have been adjusted or re-installed by authorized dealers.
- All changes and maintenance works as well as the methods used are among those specified by CFG industrial ltd.
- Only the genuine parts or accessories of CFG industrial ltd. or the parts or accessories approved by the company are used.



- Before operating the machine, the operator must have sufficient operational skills and have read up and understood the related content of the manual.
- Untrained operators may result in the risk of serious injury or personal death.
- Never use a machine without *the Operator's Manual*.
- Before operating this machine, familiarize with various warning signs, symbols and the operator's manual of this vehicle.

Installation of Communication Equipment

NOTICE

All optional electronic communication equipment must be installed by specially trained personnel in accordance with the requirements of CFG industrial ltd. specific to this machine.

Protection of Electromagnetic interference

The machine has been tested in accordance with EU89/336 EC instructions on electromagnetic interference, so it is very important that all unauthorized electronic accessories, such as communication equipment, should be tested before and after installation, because they may cause electromagnetic interference to the electronic system on the machine.

Equipment Outline

Introduction

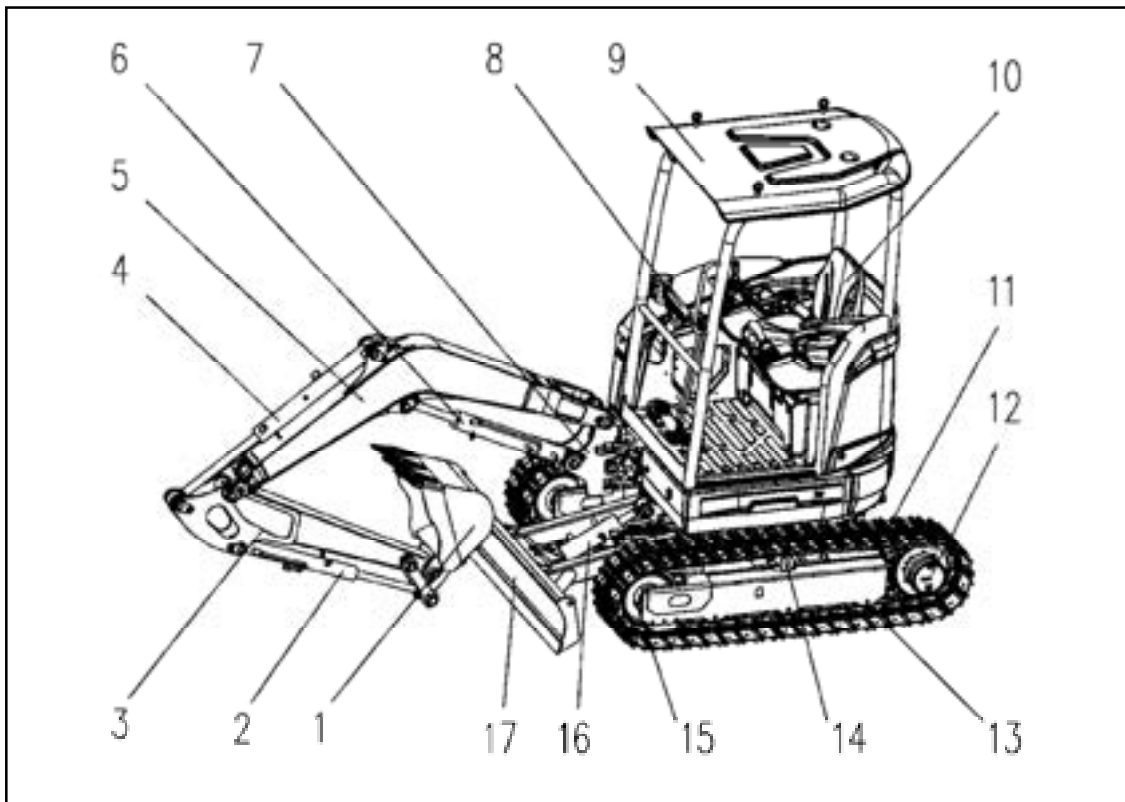

- | | |
|--------------------|--|
| 1. Bucket | 10. Seat |
| 2. Bucket cylinder | 11. Track |
| 3. Arm | 12. Traveling motor and drive sprocket |
| 4. Arm cylinder | 13. Support wheels |
| 5. Boom | 14. Towing sprocket |
| 6. Boom cylinder | 15. Increase assembly |
| 7. Yaw frame | 16. Bulldozer cylinder |
| 8. Display | 17. Bulldozer |
| 9. Driver's shed | |

Specified Use

The machine is intended to be used under normal conditions for the applications described in this manual. If it is used for other purposes or in potentially dangerous environments, for example explosive atmosphere, flammable environment or areas with dust containing asbestos and so on, special safety regulations must be followed and the machine is equipped for such use. Contact CFG industrial ltd. or dealer for further information.

Engine

Engine is 3 cylinders, 4 stroke, water-cooling, Models available as Yuma 3TNV80F or Kubota D1105.

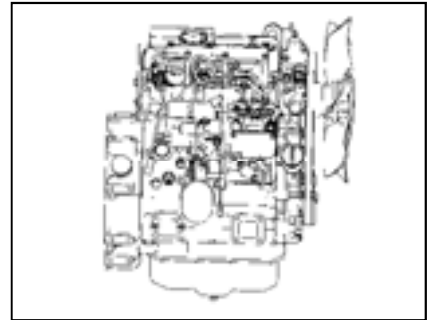

Main Pump

Hydraulic pump is a hydraulic component which converts mechanical energy into liquid pressure energy. It consists of a variable ram pump. Constant power plus load sensitive control mode is adopted.

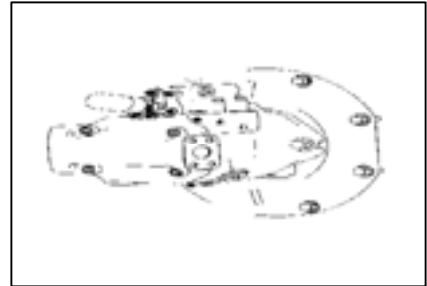

Main Valve

The main valve consists of 11 valve plates. 11 valves including first coupling valve, auxiliary valve, stick valve, boom valve, bucket valve, boom swing valve, rotary valve, left travel valve, right travel valve, bulldozing the shovel valve is connected to the end of the valve. (Please refer to the actual product for the specific order).

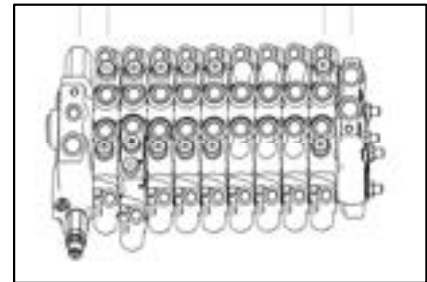

Swing Motor and Reducer

Rotary motor and reducer comprises two parts: rotary motor and reducer. The rotary motor is swash plate axial piston motor, including a plunger, swash plate, relief valve, check valve and delay valve. The reducer is composed of star gear, planet gear, pinion gear and shell. The high speed and small torque output by the rotary motor main shaft changes to low speed and large torque after being decelerated by the reducer.

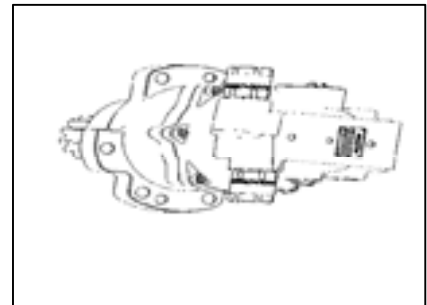

Travel Motor and Reducer

Travel motor and reducer contains the travel motor and the gear reducer. The travel motor is a swash plate axial piston motor that also include plunger, inclined plate, brake valve, balance valve, flow control valve, etc. The reducer is composed of the sun gear, the planetary gear, the pinion gear and the gear housing. The high speed and small torque output from the main shaft of the walking motor changes into low speed and large torque after deceleration by the reducer. Two-speed switching can correspond to different working conditions.

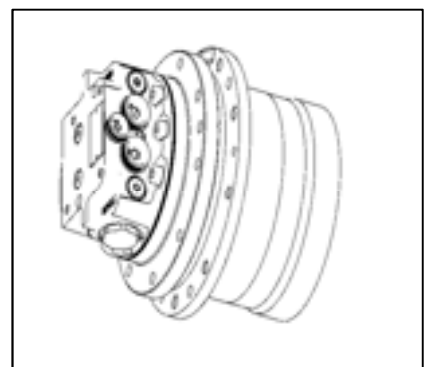

NOTE

If the above description is inconsistent with the products sold, it should be based on the substance delivered, not on this manual as the basis of the product style. If the product style or configuration changes, no notice will be given.

Directions of Machine

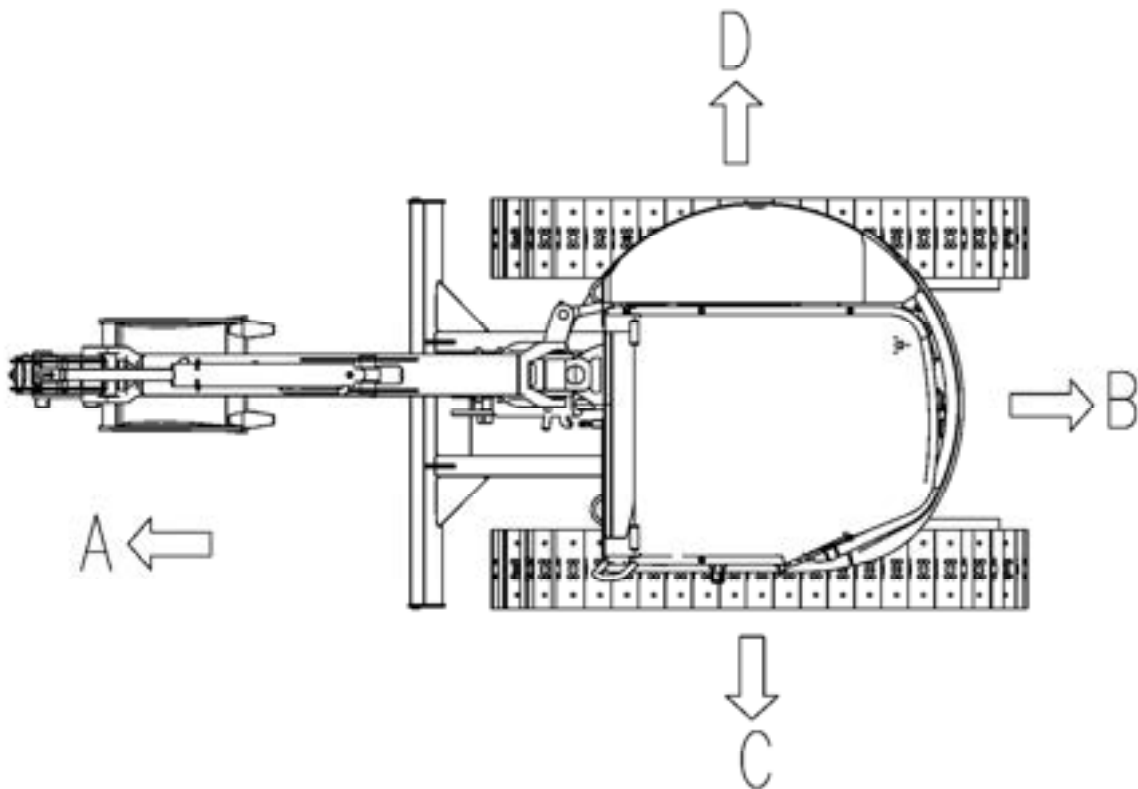

A Front

B Rear

C Left

D Right

In this operator's manual, the state of the machine's traveling direction (front) as seen from the driver's shed is the basic, which determines the front, rear, left, and right of the machine.

Product Nameplate

The following instructions and words are the product identification and nameplate on the machine. When you need to maintain the machine or order parts, please inform CFG Distributor of the following.

Located on the left front side of the rack.

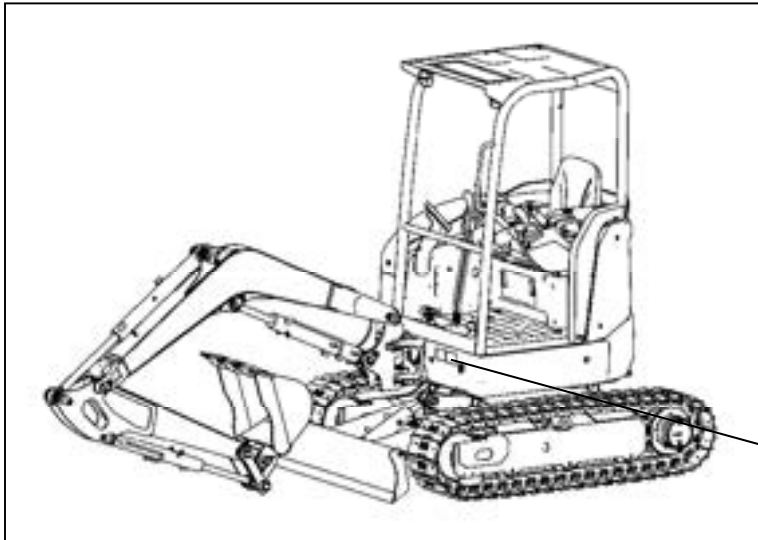

Engine Number Plate

On the top of the engine cylinder head cover.

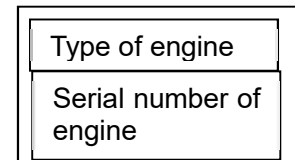
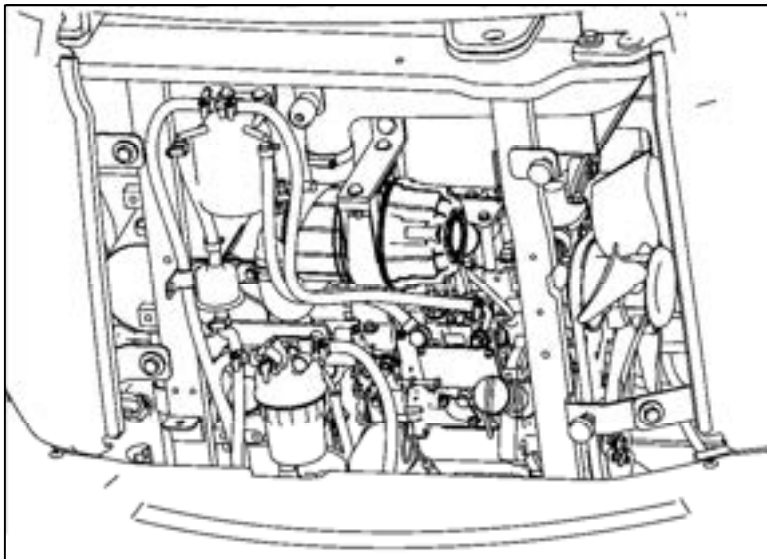

Service Meter Location

The select area in the white box of the monitor is the display of the “working time” .



The Machine Serial Numbers and Distributor

Machine serial No.	
Product identification number (PIN)	
Engine serial No.	
Distributor name	
Address	
Phone/Fax	
Service Personnel	

CONTENTS

FOREWORD	I
Foreword.....	II
Safety Regulations.....	III
Vehicle Operation and Maintenance.....	III
Installation of Communication Equipment.....	III
Protection of Electromagnetic interference.....	III
Equipment Outline.....	IV
Introduction.....	IV
Specified Use.....	IV
Engine.....	V
Main Pump.....	V
Main Valve.....	V
Swing Motor and Reducer.....	V
Travel Motor and Reducer.....	V
Directions of Machine.....	VI
Product Nameplate.....	VII
Engine Number Plate.....	VII
Service Meter Location.....	VIII
The Machine Serial Numbers and Distributor.....	VIII
CONTENTS.....	I
SAFETY	1
Safety Labels.....	2
Location of Safety Labels.....	2
Safety Labels.....	3
Basic Safety Information.....	9
Safety Machine Operation.....	16
Starting Engine.....	16
Operation.....	16
Transport.....	22
Battery.....	23
Towing.....	25
Lifting Work.....	25
Safety Maintenance Information.....	26
OPERATION	33
General Drawing of Control Device.....	34
Description of Instrument and Control Device.....	35
Monitor.....	35
Trouble Shooting and Investigation.....	45
Other Control Devices.....	45
Equipment Lock.....	48
Battery Disconnect Switch.....	48

Fuse	49
Radio.....	50
Air Conditioner System	53
Machine Operations and Controls	54
Before Starting Engine.....	54
Checks before Starting	55
Adjustment	60
Operations before Starting Engine.....	61
Starting Engine.....	62
After Starting Engine	64
Stopping the Engine	65
Machine Operation: Move and Stop.....	66
Steering the Machine.....	68
Swinging.....	69
Work Equipment Controls and Operations.....	69
Operation with Hook Bucket	71
Prohibited Operations.....	72
General Operation Information	74
Traveling on Slopes	75
Traveling Downhill	76
Recommended Applications	77
Bucket Replacement and Inversion	78
Parking Machine.....	79
Check After Completion of the Job	80
Locking.....	80
Rubber Pad Shoe and Road Liner.....	81
Transportation.....	85
Transportation Procedure	85
Loading and Unloading with Trailer.....	85
Cold Weather Operation	89
Cold Weather Operation Information	89
After Daily Work Completion.....	90
After Cold Weather Season	90
Long Term Storage	91
Before Storage	91
During Storage	91
After Storage	91
Troubles and Actions	92
Running out of Fuel	92
Phenomena that are not Failures.....	92
Towing the Machine.....	93
Lightweight Towing Hole.....	93
Severe Job Condition	93
Battery Discharges and Charges	94
Starting Engine with Booster Cables.....	96

Others Malfunction	97
MAINTENANCE.....	101
Maintenance Information.....	102
Lubricants, Fuels and Coolants.....	104
Lubricants	104
Fuel.....	104
Storing Oil and Fuel.....	104
Grease	105
Coolant of the cooling system	105
Filters	105
Electric System Maintenance.....	105
Maintenance of Hydraulic System.....	106
Wear Parts	106
Wear Parts List.....	107
Use the Recommended Fuel, Coolant and Lubricants.....	107
Correct Selection.....	108
Tightening Torque Specifications	109
Regular Replacement of Safety Critical Parts	110
Safety critical parts.....	110
Maintenance schedule	111
Maintenance schedule	111
Maintenance Interval for Hydraulic Breaker.....	113
Maintenance procedures	114
Engine maintenance and maintenance.....	114
Fuel system maintenance and maintenance	115
Maintenance of cooling system	117
Air filter maintenance and maintenance.....	119
Operation instructions for electric welding	123
Maintenance of Hydraulic System	124
Crawler tension- inspect/adjustment Machine with metal treads.....	128
Replace Bucket Teeth	128
Working Device Grease - filling	128
Maintenance and Lubrication of Lock Core	129
Maintenance and Lubrication of Hinge	129
Slewing and Pinion Grease - Check/Refill	130
SPECIFICATION	131
Specifications.....	132
Working Ranges	134
Standard Configuration and Digging Force	135
Operating Weight and Ground Specific Pressure	135
Disclaimer	135
ATTACHMENTS AND OPTIONS	137
Safety First.....	138

Attachment Installation	139
Recommended Attachment Operations	140
Hydraulic Breaker	140
Prohibited Works	142
Supply Grease in the Correct Position	144

SAFETY

 A white warning triangle icon with a black exclamation mark inside, set against a black background.**WARNING**

Please read and make sure that you fully understand the precautions described in this manual and the safety labels on the machine. When operating, maintaining and inspecting the machine, always follow these precautions strictly.

Safety Labels

The following warning signs and safety labels are used on this machine.

- Be sure that you fully understand the correct position and content of labels.
- To ensure that the content of labels can be read properly, be sure that they are in the correct place and always keep them clean.
- There are also other labels in addition to the warning signs and safety labels. Handle those labels in the same way.
- If the labels are damaged, lost, or cannot be read properly, place an order with CFG distributor.

Location of Safety Labels

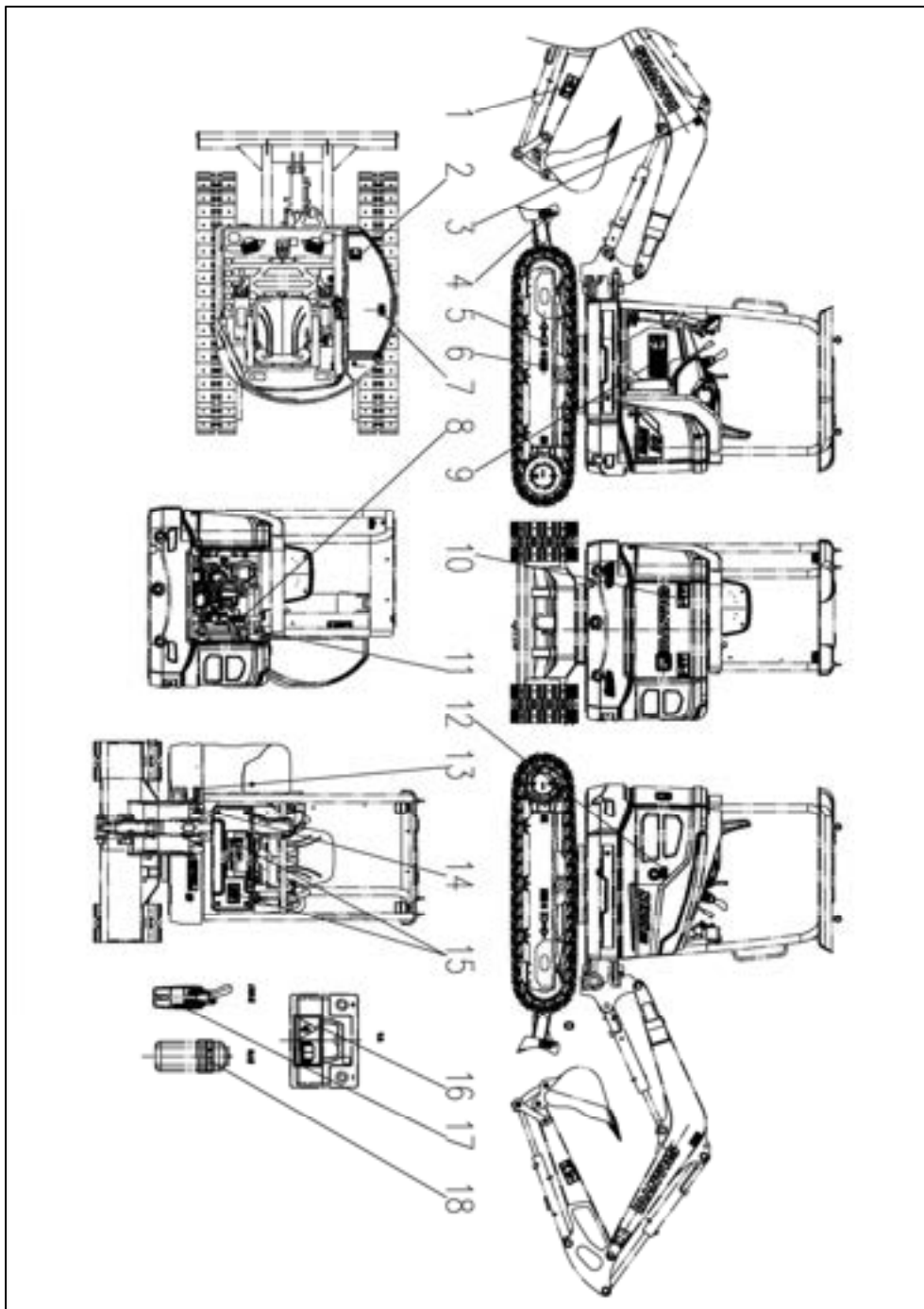

Safety Labels

1. Beware of work equipment (09134-10880)
 - Sign indicates a hazard of being hit by the working Device of the machine.
 - Keep away from machine during operation.

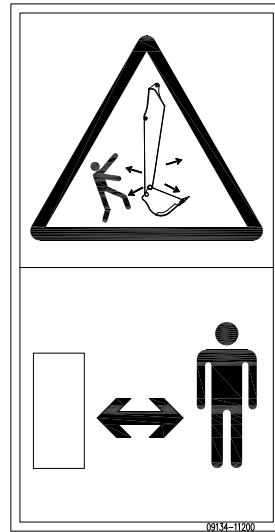

2. Dangerous signs for fuel filling (09843-01000)



3. Lifting position sign (09960-01001)

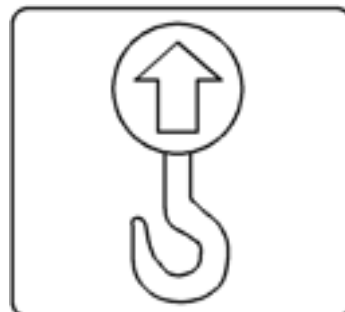

4. Fixed position sign (09960-01002)

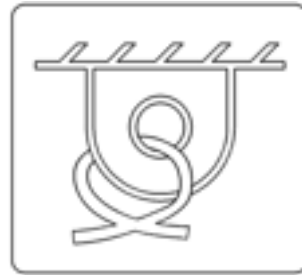

5. Direction sign (09951-00200)



6. Note signs for track adjustment (09657-10880)

- The screw plug of the track shoe tension adjustment device will fly out and cause injury.
- When adjusting the track tension, read this driver's manual and follow the correct method.

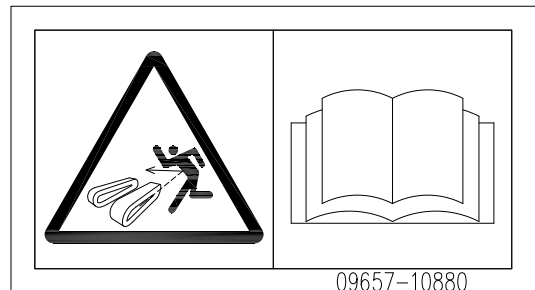

7. Breathing valve maintenance notice label (09841-01000)



8. Safety notice plate (09653-10480)

- Do not remove the cover when the engine is at operating (high) temperature. Steam or hot oil from a radiator or hydraulic tank can cause injuries or burns.
- When cooling water or hydraulic oil is at high temperature, do not remove the radiator cover or hydraulic tank filler cover.

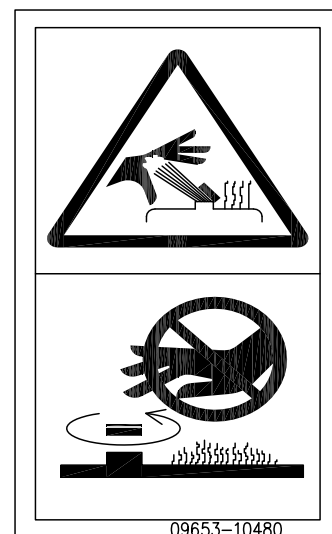

9. Maintenance and replacement table

No.	Maintenance Name	Hours and Intervals							Remarks	Qty	
		Every Day	After 50h	After 100/200/300/400/500/600/700/800/900/1000/1100/1200/1300/1400/1500/1600/1700/1800/1900/2000/2100/2200/2300/2400/2500/2600/2700/2800/2900/3000/3100/3200/3300/3400/3500/3600/3700/3800/3900/4000/4100/4200/4300/4400/4500/4600/4700/4800/4900/5000/5100/5200/5300/5400/5500/5600/5700/5800/5900/6000/6100/6200/6300/6400/6500/6600/6700/6800/6900/7000/7100/7200/7300/7400/7500/7600/7700/7800/7900/8000/8100/8200/8300/8400/8500/8600/8700/8800/8900/9000/9100/9200/9300/9400/9500/9600/9700/9800/9900/10000							
1	Working Device Pin	*								Crosses W:1.0/1.0	
2	Working Device Pin	*								Crosses W:1.0/1.0	
3	Control	*								-45g Every 3000h	5L
4	Roller	*								Replenish Grease	
5	Engine Oil	*	*							API SAE 4 SAE 15W-40	3.4L
6	Engine Oil Filter	*	*							Filter	1
7	Fuel	*								50L/20	20L
8	Water & Fuel/Water & Fuel Tank	*									
9	Fuel Filter	*								Filter	1
10	Distributor Synchroizer	*	*							Filter	1
11	Hydraulic Oil	*								ISO VG46	22L
12	Return Filter	*								Filter	1
13	Breather Valve Filter	*								Filter	1
14	Suction Filter	*								Filter	1
15	Flux Filter	*								Filter	1
16	Swivel Valve	*								API SAE 4 SAE 15W-40	200.0L
17	Air Conditioning Filter	*								Filter	1 each

* Check and Tighten
 * Check and Clean
 * Replace

NOTICE: 1. Stop engine for maintenance and replacement. 2. Please refer to the Operator's Manual for other details.

10. Safety notice sign for turning area (09133-11680)

- Do not enter the turning area of the machine when the upper part of the machine is turning.
- There is a danger of collision when the platform rotates.

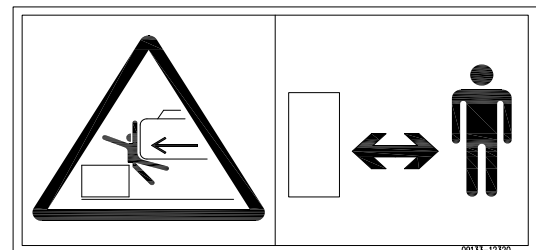

11. Note signs for engine operation (09667-20640)

- When the fan is running, it is forbidden to touch or repair it.
- After stopping the operation, perform maintenance.

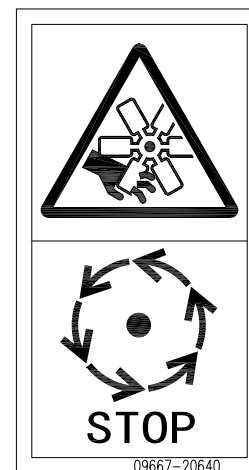

12. Hydraulic oil level check posture sign (09840-02000)



13. Lubrication plate of slewing bearing (09845-02000)

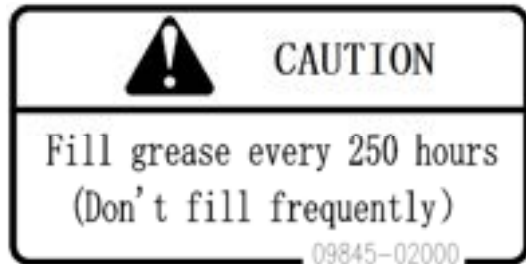

14. Filling position sign

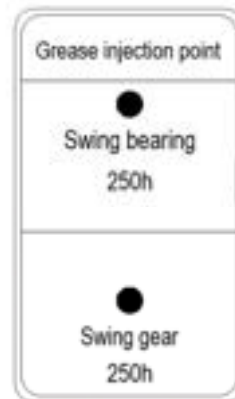

15.

(1) Note signs before operation (09651-10480)

- Read the driver's manual before operation, maintenance, assembly and transportation



(2) Start and stop safety signs (09654-30480)

- The sudden movement of the stopped machine may cause the danger of being caught or run over by the machine. When leaving the machine, lower the working device to the ground,
- Move the safety lock lever to the locked position and remove the engine key.



(3) High Voltage Attention Sign (09801-20480)

- If the machine is close to high-voltage cables, it may cause electric shock to the operator.
- Keep a safe distance between the machine and the cable.

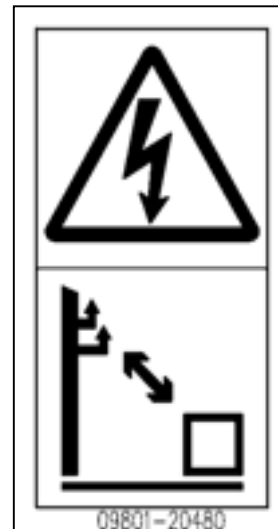

(4) Caution signs before reversing (09802-22000)



(5) Caution for operating pattern (ISO mode) (09822-02000)

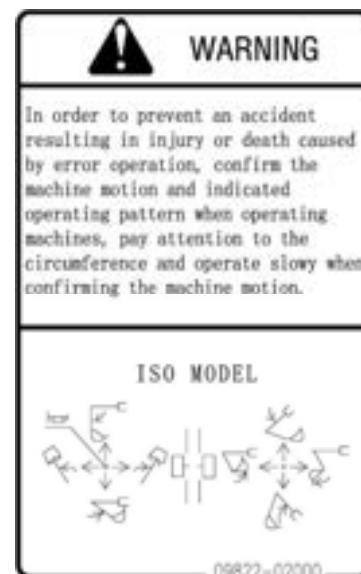

16. Notice plate to prevent electric shock (09808-10880)



17. Joystick lock sign (09685-00001)

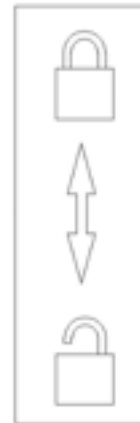

18. Coolant pay attention to the label (09848-02000)

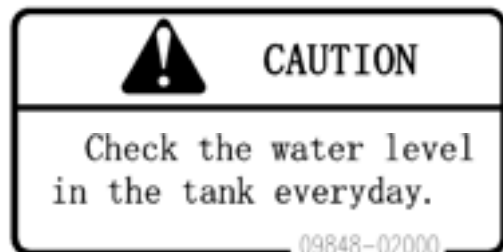

Basic Safety Information

Safety Rules

- Only trained and authorized personnel can operate and maintain the machine.
- Follow all safety rules, precautions and instructions when operating or performing maintenance on the machine.
- Do not operate the machine if you are in poor physical condition and mental instability, under the influence of drugs (easily drowsy) or alcohol.
- When working with another operator or configuring a signal person, be sure that all personnel understand all hand signals that are to be used.

If Problems Are Found

If you find any problems in the machine during operation or maintenance (noise, vibration, smell, incorrect gauges, smoke, oil leakage, etc., or any abnormal display on the warning devices or monitor), report to the person in charge and have the necessary action taken. Do not operate the machine until the problem has been corrected.

Working Wear and Personal Protective Items

- Do not wear loose clothing and accessories. There is a hazard that they may catch on control levers or other protruding parts.
- If you have long hair and it hangs out from your hard hat, there is a hazard that it may get caught up in the machine, so tie your hair up and be careful not to let it get caught.
- Always wear a hard hat and safety shoes. If the nature of the work requires it, wear safety glasses, mask, gloves, ear plugs, and safety belt when operating or maintaining the machine.
- Check that all protective equipment functions properly before using it.



Fire Extinguisher and First Aid Kit

Always follow the precautions below to prepare for action if any injury or fire should occur.

- Be sure that fire extinguishers have been provided and ensure that you know their use well in emergencies.
- Carry out periodic inspection and maintenance to ensure that the fire extinguisher can always be used.
- Provide a first aid kit in the storage point. Carry out periodic checks and add to the contents if necessary.

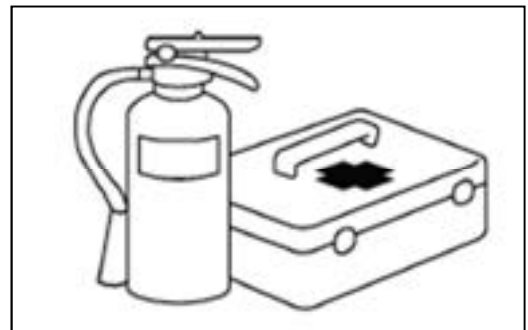

Safety Equipment

- Be sure that all guards, covers and rear view mirror are in their proper position. Have guards and covers repaired immediately if they are damaged.
- Understand the method of use of safety features and use them properly.
- Never remove any safety features. Always keep them in good operating condition.

Keep Machine Clean

- If water gets into the electrical system, there is a hazard that it will cause malfunctions or disoperation. Do not use water or steam to wash the electrical system (sensors, alternators, solenoid valves, connectors).
- If inspection and maintenance is carried out when the machine is still dirty with mud or oil, there is a hazard that you will slip and fall, or that dirt or mud will get into your eyes. Always keep the machine clean.



WARNING

When cleaning the engine around, the following two cannot be cleaned and splashed liquid, otherwise it will cause damage of engine parts.

- 1 Generator; 2 Starting motor

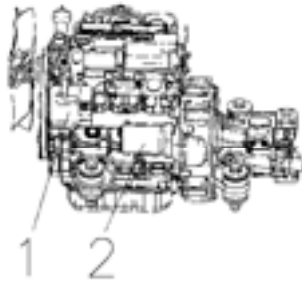

Precautions of Standing up or Leaving from the Operator's Seat

- Before standing up from the seat (for example, when adjusting the seat, etc.), lower the working device to the ground completely. At the same time, move the lock lever to the locked position, and then turn off the engine. If you accidentally touch the unlocked joystick, the machine may move suddenly and cause a serious personal accident.
- When leaving the machine, you must lower the working device and the bulldozer to the ground, place the lock lever in the locked position, and stop the engine. In addition, lock all equipment with a key. Take down the key and put it in the specified position.

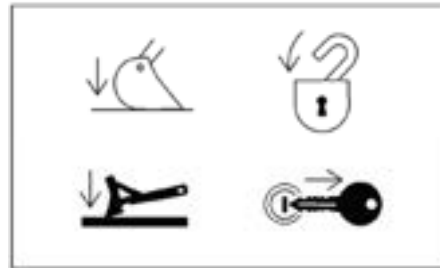

Use Handrails and Stairs Leaving Operator's Seat

To prevent personal injury caused by slipping or falling off the machine, always do as follows:

- To ensure safety, always face the machine and maintain three-point contact (both feet and one hand, or both hands and one foot) with the handrails and steps (including the track shoe) to ensure that you support yourself.
- Do not grip the control levers or lock lever when getting on or off the machine.
- Never climb on the engine hood or cover that does not have anti-skid devices.
- Before getting on or off the machine, check the handrails and steps (including the track shoe). If there is any oil, grease, or mud on the handrails or steps (including the track shoe), wipe it off immediately. Always keep these parts clean. Repair any damage and tighten any loose bolts.
- Do not get on or off the machine while holding tools in your hands.

Forbidden to Jump On or Off the Machine

- Never jump on or off the machine. Never get on or off a moving machine.
- If the machine starts to move when there is no operator on the machine, do not jump on to the machine and try to stop it.

No Persons on Attachments

Never let anyone ride on the work equipment, or other attachments. There is a hazard of falling and suffering serious injury.

Not to Be Pinched

Due to the action of the connecting rod, the peripheral clearance of the working device will change. If caught, it may cause a serious personal accident. Personnel are not allowed to approach all rotating and telescopic parts.

Burn Prevention

Hot coolant

- To prevent burns from hot water or steam spurting out when checking or draining the coolant, wait for the water to cool to a temperature where it is possible to touch the radiator cap by hand before starting the operation. Even when the coolant has cooled down, loosen the cap slowly to relieve the pressure inside the radiator before removing the cap.



Hot oil

- To prevent burns from hot oil spurting out when checking or draining the oil, wait for the oil to cool to a temperature where it is possible to touch the cap or plug by hand before starting the operation. Even when the oil has cooled down, loosen the cap or plug slowly to relieve the internal pressure before removing the cap or plug.



Fire prevention and Explosion Prevention

Fire caused by fuel or oil.

Fuel, oil, antifreeze, and window washer liquid are particularly flammable and can be hazardous. To prevent fire, always observe the following:

- Do not smoke or use any flame near fuel or oil.
- Stop the engine before refueling.
- Do not leave the machine while adding fuel or oil.
- Tighten all fuel and oil caps securely.
- Do not spill fuel on overheated surfaces or on parts of the electrical system.
- Use well-ventilated areas for adding or storing oil and fuel.
- Keep oil and fuel in the determined place and do not allow unauthorized persons to enter.



- After adding fuel or oil, wipe up any spilled fuel or oil.
- When carrying out grinding or welding work on the machine, move any flammable materials to a safe place before starting.
- When washing parts with oil, use a non-flammable oil. Diesel oil and gasoline may catch fire, so do not use them.

- Put greasy rags and other flammable materials into a safe container to maintain safety at the work place.
- Do not weld or use a cutting torch to cut any pipes or tubes that contain flammable liquids.

Fire Caused by Accumulation of Flammable Material.

Remove any dry leaves, chips, pieces of paper, dust, or any other flammable materials accumulated or affixed around the engine, exhaust manifold, muffler, or battery, or inside of the machine.

Fire coming from electric wiring

Short circuits in the electrical system can cause fire.

- Always keep electric wiring connections clean and securely tightened.
- Check the wiring every day for looseness or damage. Tighten any loose connectors or wiring clamps. Repair or replace any damaged wiring.

Fire caused by piping

Check that all hoses and pipe clamps, shields and cushions are firmly fixed in place. If loosened, vibration and friction with other parts will occur during operation, resulting in damage to hoses, high-pressure oil ejection, fire hazards or personal accidents.

Explosion Caused by Lighting Equipment

- When checking fuel, oil, battery electrolyte, window washer fluid, or coolant, always use lighting with anti-explosion specifications. If such lighting equipment is not used, there is danger of explosion that may cause serious injury.
- When taking the electrical power for the lighting from the machine itself, follow the instructions in this manual.

Action in Case of Fire

If fire occurs, escape from the machine as follows.

- Turn the start switch OFF to stop the engine.
- Use the handrails and steps to get off the machine.

Falling Objects, Flying Objects and Intruding Objects Prevention

- On jobsite there is a hazard that falling objects, flying objects, or intruding objects may hit or enter the operator's cab, consider the operating conditions and install the necessary guards to protect the operator.
- When carrying out demolition or breaker operation, install a front guard and use a laminated coating sheet on the front.
- When working in mines or quarries where there is a hazard of falling rock, install FOPS (Falling Objects Protective Structure) and a front guard, and use a laminated coating sheet on the front glass.
- When carrying out the above operations, always close the front window. In addition, always ensure that standers-by are a safe distance away and are not in hazard from falling or flying objects.



- The above recommendations assume that the conditions are for standard operations, but it may be necessary to add additional guards according to the operating conditions on the jobsite. Always contact your CFG distributor for advice.

Attachment Installation

- When installing optional parts or attachments, there may be problems with safety or legal restrictions. Therefore, contact your CFG distributor for advice.
- Any injuries, accidents, or product failures resulting from the use of unauthorized attachments or parts will not be the responsibility of CFG.
- When installing and using optional attachments, read the instruction manual for the attachment, and the general information related to attachments in this manual.

Attachment Combinations

Depending on the type or combination of work equipment, there is a hazard that the work equipment may hit the driving shed or other parts of the machine. Before using unfamiliar work equipment, check if there is any hazard of interference, and operate with caution.

Unauthorized modifications

Any modification made without authorization from CFG can create hazards. Before making a modification, consult your CFG distributor.

- CFG will not be responsible for any injuries, accidents, product failures or other property damages resulting from modifications made without authorization from CFG.

Safety on the Job site

Before starting operations, thoroughly check the area for any unusual conditions that could be dangerous.

- When carrying out operations near combustible materials such as thatched roofs, dry leaves or dry grass, there is a hazard of fire, so be careful when operating.
- Check the terrain and condition of the ground at the jobsite, and determine the safest method of operation. Do not operate where there is a hazard of landslides or falling rocks.
- If water lines, gas lines, or high-voltage electrical lines may be buried under the job site, contact each utility and identify their locations. Be careful not to sever or damage any of these lines.
- Take action to prevent unauthorized people from approaching the job site. When working on public roads, position flagmen and erect barriers to ensure the safety of passing traffic and pedestrians.
- When traveling or operating in shallow water or on soft ground, check the shape and condition of the bedrock, and the depth and speed of flow of the water before starting operations.

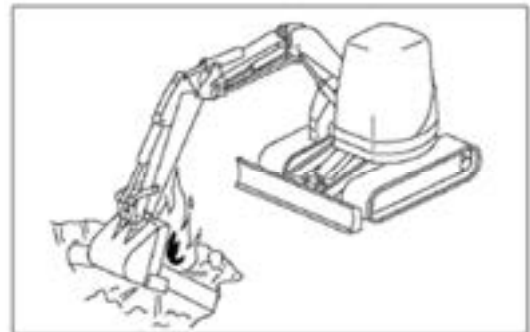

Prevent the machine tipping over

- Avoid traveling or operating your machine too close to the edge of cliffs, overhangs, and deep ditches. The ground may be weak in such areas. If the ground should collapse under the weight or vibration of the machine, there is a hazard that the machine may fall or tip over. Remember that the soil after heavy rain or blasting or after earthquakes is weak in these areas.
- When working on embankments or near excavated ditches, there is a hazard that the weight and vibration of the machine will cause the soil to collapse. Before starting operations, take steps to ensure that the ground is safe and to prevent the machine from rolling over or falling.

Distance to High Voltage Cables

Do not travel or operate the machine near electric cables. There is a hazard of electric shock, which may cause serious injury or property damage. On jobsites where the machine may go close to electric cables, always do as follows.

- Before starting work near electric cables, inform the local power company of the work to be performed, and ask them to take the necessary action.
- Even going close to high-voltage cables can cause electric shock. Always maintain a safe distance (see the table) between the machine and the electric cable. Check with the local power company about safe operating procedure before starting operations.
- To prepare for any possible emergencies, wear rubber shoes and gloves. Lay a rubber sheet on top of the seat, and be careful not to touch the chassis with any exposed part of your body.
- Use a signalman to give warning if the machine approaches too close to the electric cables.
- When carrying out operations near high voltage cables, do not let anyone near the machine.
- If the machine should come too close or touch the electric cable, to prevent electric shock, the operator should not leave the operator's compartment until it has been confirmed that the electricity has been shut off. Also, do not let anyone near the machine.



	Voltage of Cables	Safety Distance
Low voltage	100 V - 200 V	Over 2 m (7 ft)
	6600V	Over 2 m (7 ft)
Extra high voltage	22000 V	Over 3 m (10 ft)
	66000 V	Over 4 m (14ft)
	154000 V	Over 5 m (17 ft)
	187000 V	Over 6 m (20 ft)
	275000 V	Over 7 m (23 ft)
	500000 V	Over 11 m (36 ft)

Ensure Good Visibility

Check for any persons or obstacles in the area around the machine and check the conditions of the job site to ensure that operations and travel can be carried out safely. Always do as follows.

- When working in dark places, turn on the working lamp and front lamps installed to the machine, and set up additional lighting in the work area if necessary.
- Stop operations if the visibility is poor, such as in mist, snow, rain, or dust.

Ventilation for Enclosed Area

If it is necessary to start the engine within an enclosed area, or when handling fuel, flushing oil, or paint, open the doors and windows to ensure that adequate ventilation is provided to prevent gas poisoning.

Signalman's Signal and Signs

- Set up signs to inform of road shoulders and soft ground. If the visibility is not good, position a signalman if necessary. Operators should pay careful attention to the signs and follow the instructions from the signalman.
- Only one signalman should give signals.
- Make sure that all workers understand the meaning of all signals and signs before starting work.

Asbestos Dust Hazard Prevention

Asbestos dust in the air can cause lung cancer if it is inhaled. There is danger of inhaling asbestos when working on job sites handling demolition work or work handling industrial waste. Always observe the following.

- Spray water to keep down the dust when cleaning. Do not use compressed air for cleaning.
- If there is danger that there may be asbestos dust in the air, always operate the machine from an upwind position. All workers should use an approved respirator.
- All personnel should use dust masks.
- Do not allow other persons to approach during the operation.
- Always observe the rules and regulations for the work site and environmental standards.
- This machine does not use asbestos, but there is a danger that imitation parts may contain asbestos, so always use genuine CFG parts.



Safety Machine Operation

Starting Engine

If there is a warning tag hanging from the work equipment control lever, do not start the engine or touch the levers.

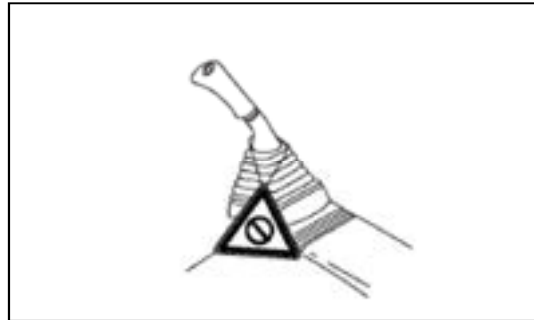

Checks before Starting Engine

Carry out the following checks before starting the engine at the beginning of the day's work.

- Remove all dirt from the surface of the window glass to ensure a good view.
- Remove all dirt from the surface of the lens of the working lamps, and check that they light up correctly.
- Check the coolant level, fuel level, and oil level in engine oil pan, check for clogging of the air cleaner, and check for damage to the electric wiring.
- Adjust the operator's seat to a position where it is easy to carry out operations, and check that there is no damage or wear to the seat belt or mounting clamps.
- Check the operation of the instruments and gauges, check the angle of the mirror, and check that the control levers are all at the Neutral position.
- Before starting the engine, check that lock lever is in LOCK position.
- Check that there are no persons or obstacles above, below, or in the area around the machine.

Safety rules for Starting Engine

- Start and operate the machine only while seated.
- Do not attempt to start the engine by short-circuiting the engine starting circuit. Such an act may cause a serious bodily injury or fire.
- When starting the engine, sound the speaking as a warning.
- Do not allow anyone apart from the operator to ride on the machine.

Starting Engine in Cold Weather

- Carry out the warming-up operation thoroughly. If the machine is not thoroughly warmed up before the control levers or control pedals are operated, the reaction of the machine will be slow or the machine may move in a way not expected by the operator.
- If the battery electrolyte is frozen, do not charge the battery or start the engine with a different power source. There is a hazard that this will ignite the battery and cause the battery to explode.
- Before charging or starting the engine with a different power source, melt the battery electrolyte and check that there is no leakage of electrolyte before starting.

Operation

Checks before Operation

When carrying out the checks, move the machine to a wide area where there are no obstructions, and operate slowly. Do not allow anyone near the machine.

- Always fasten your seat belt.
- Check that the movement of the machine matches the display on the control pattern card. If it does not match, replace it immediately with the correct control pattern card.
- Check the operation of the gauges and equipment, and check the operation of the bucket, arm, boom, travel system, swing system, and steering system.
- Check for any problem in the sound of the machine, vibration, heat, smell, or gauges; check that whether there is leakage of oil or fuel or not.
- If any problem is found, carry out repairs immediately.

Safety Rules for Changing Machine Directions

Before traveling, set the machine so that sprocket ① is behind the operator's seat. If sprocket ① is in front of the operator's seat, the machine is in the opposite direction from the operation of the lever (front and rear travel is reversed, left and right steering is reversed). Be extremely careful when operating the machine in this situation.

- Before traveling, check again that there is no one in the surrounding area, and that there are no obstacles.
- Before traveling, sound the speaker to warn people in the area.
- Always operate the machine only when seated.
- Do not allow anyone apart from the operator to ride on the machine.
- If there is an area to the rear of the machine which cannot be seen, position a signal person. Take special care so as not to hit other machines or people when turning or swinging the machine.
- Check that the travel alarm (optional) works properly.

Always be sure to carry out the above precautions even when the machine is equipped with mirrors.

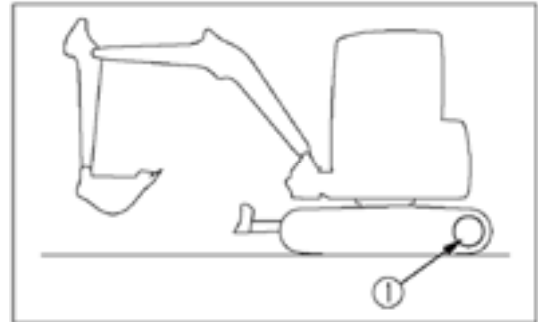

Safety Rules for Traveling

- Do not operate the machine too quickly, suddenly start, stop or turn.
- When traveling on flat ground, keep the work equipment 40 to 50cm high above the ground.
- When traveling on rough ground, travel at low speed and do not operate the steering suddenly. There is danger that the machine may turn over. The work equipment may hit the ground surface

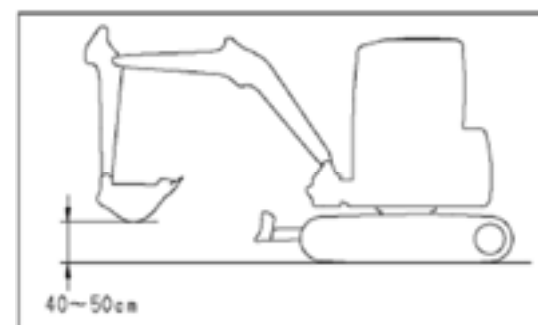

and cause the machine to lose its balance, or may damage the machine or structures in the area.

- Avoid traveling over obstacles when possible. If the machine has to travel over an obstacle, keep the work equipment close to the ground and travel at low speed. Never travel over obstacles which make the machine tilt strongly to one side.
- When traveling or carrying out operations, always keep a safe distance from people, structures, or other machines to avoid coming into contact with them.
- When passing over bridges or structures, check first that the structure is strong enough to support the weight of the machine. In addition, when walking on the highway, first ask the relevant authorities to check and follow their instructions.
- When operating in tunnels, under bridges, under electric wires, or other places where the height is limited, operate slowly and be extremely careful not to let the work equipment hit anything.
- Do not let the machine or working device touch anything.



Traveling on Slopes

To prevent the machine from tipping over or slipping to the side, always do as follows.

- Keep the work equipment approx. 20 to 30 cm above the ground. In case of emergency, lower the work equipment to the ground immediately to help stop the machine.

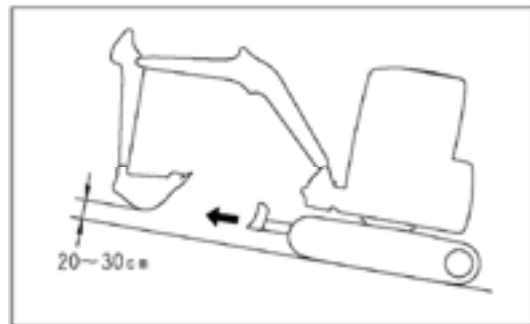

- When traveling up slopes, set the driver's shed facing uphill, when travel down slopes, set the driver's shed facing downhill. Always check the firmness of the ground under the front of the machine when traveling.

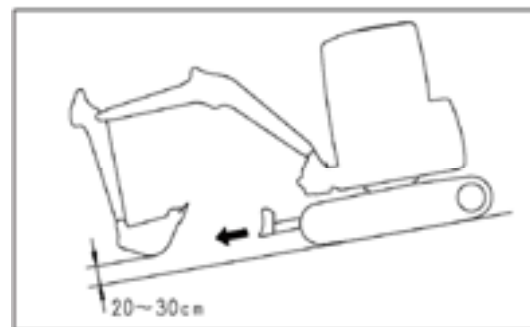

- When traveling up a steep slope, extend the work equipment to the front to improve the balance, keep the work equipment approximately 20 to 30 cm above the ground, and travel at low speed.

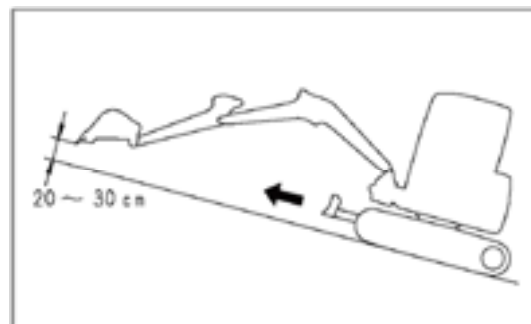

- When traveling downhill, lower the engine speed, keep the travel lever close to the neutral position, and travel at low speed. When walking downhill on a slope with a slope of 15° or more, as shown in the right figure, place the driving wheel ① on the downhill side, reduce the engine speed and walk.

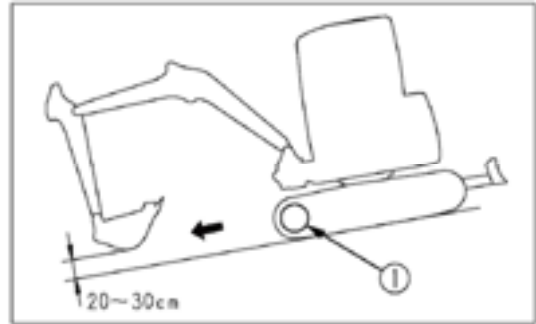

- Always travel straight up or down a slope. Traveling at an angle or across the slope is extremely dangerous.
- Do not turn on slopes or travel across slopes. Always go down to a flat place to change the position of the machine, then travel on to the slope again.
- Travel on grass, fallen leaves, or wet steel plates with low speed. Even with slight slopes there is a hazard that the machine may slip.
- If the engine stops when the machine is traveling on a slope, move the control levers immediately to the neutral position and start the engine again.

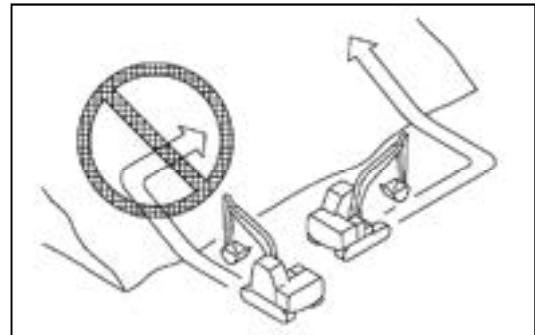

Operations on Slopes

- When working on slopes, there is a hazard that the machine may lose its balance and turn over when the swing or work equipment are operated. This may lead to serious injury or property damage, so always provide a stable place when carrying out these operations, and operate carefully.
- Do not swing the work equipment from the uphill side to the downhill side when the bucket is loaded. This operation is dangerous, and may cause the machine to tip over.
- If the machine has to be used on a slope, pile the soil to make a platform (A) that will keep the machine as horizontal as possible.

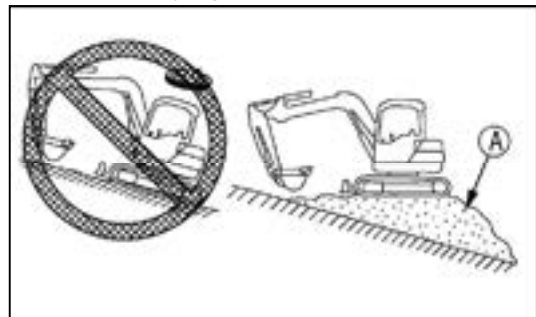

Prohibited Operations

- Never dig the work face under an overhang. There is a hazard that rocks may fall or that the overhang may collapse and fall on top of the machine.

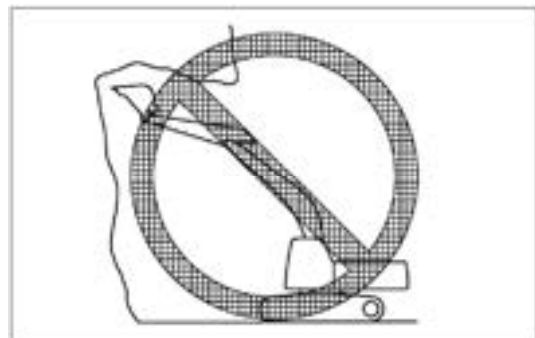

- Do not excavate too deeply under the front of the machine. The ground under the machine may collapse and cause the machine to fall.

- To make it easier to escape if there is any problem, set the tracks at right angles to the road shoulder or cliff with the sprocket at the rear when carrying out operations.

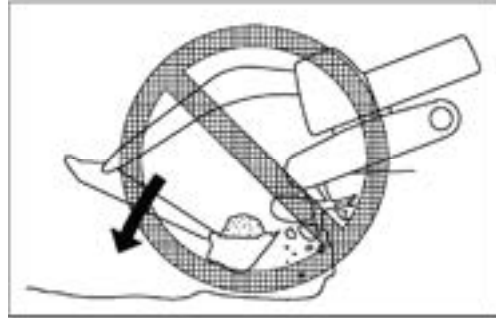

- Do not carry out demolition work under the machine. There is a hazard that the machine may become unstable and tip over.
- When working on or from the top of buildings or other structures, check the strength and the structure before starting operations. There is a hazard of the building collapsing and causing serious injury or damage.

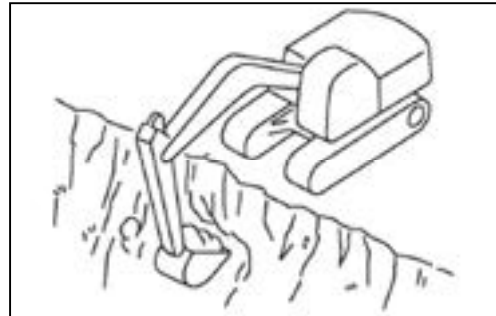

- When carrying out demolition work, do not carry out demolition above your head. There is a hazard of broken parts falling or of the building collapsing and causing serious injury or property damage.

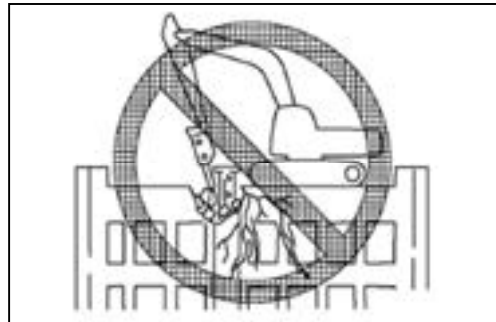

Do not use the impact force of the work equipment for breaking work. There is a hazard of damage to the work equipment, or a hazard of serious personal injury being caused by flying pieces of broken materials, or of the machine tipping over due to reaction from the impact.

- Generally speaking, the machine is more liable to overturn when the work equipment is at the side than when it is at the front or rear.

- When using a breaker or other heavy work equipment, there is a hazard of the machine losing its

balance and tipping over. When operating on flat ground as well as on slopes.

- Do not suddenly lower, swing, or stop the work equipment.

- Do not suddenly extend or retract the boom cylinder. There is a hazard that impact will cause the machine to tip over.

- Do not pass the bucket over the head of other workers or over the operator's seat of dump trucks or other hauling equipment. The load may spill or the bucket may hit the dump truck and cause serious injury or property damage.

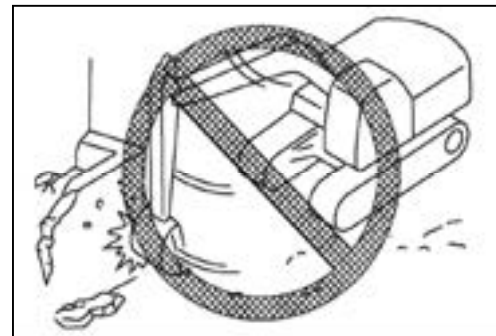
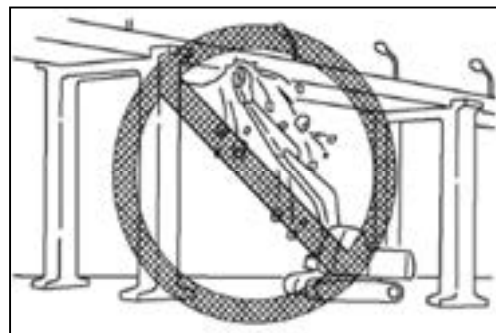

Operations on Snow

- Snow-covered or frozen surfaces are slippery, so be extremely careful when traveling or operating the machine, and do not operate the levers suddenly. Even a slight slope may cause the machine to slip, so be particularly careful when working on slopes.
- With frozen ground surfaces, the ground becomes soft when the temperature rises, and this may cause the machine to tip over.
- If the machine enters deep snow, there is a hazard that it may tip over or become buried in the snow. Be careful not to leave the road shoulder or to get trapped in a snow drift.
- When clearing snow, the road shoulder and objects placed beside the road are buried in the snow and cannot be seen. There is a hazard of the machine tipping over or hitting covered objects, so always carry out operations carefully.

Parking Machine

- Park the machine on firm, level ground.
- Select a place where there is no hazard of falling rocks or landslides, or of flooding if the land is low.
- Lower the work equipment completely to the ground.

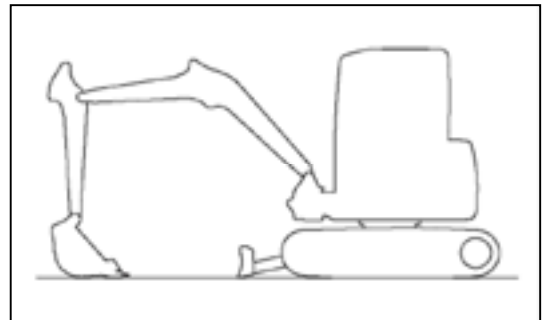

- When leaving the machine, set lock lever to the LOCK position, then stop the engine.
- Always close the operator's cab door, and use the key to lock all the equipment in order to prevent any unauthorized person from moving the machine. Always remove the key, take it with you, and leave it in the specified place.



- If it is necessary to park the machine on a slope, always do as follows.
 - Set the bucket on the downhill side, then dig it into the ground.
 - Put blocks under the tracks to prevent the machine from moving.

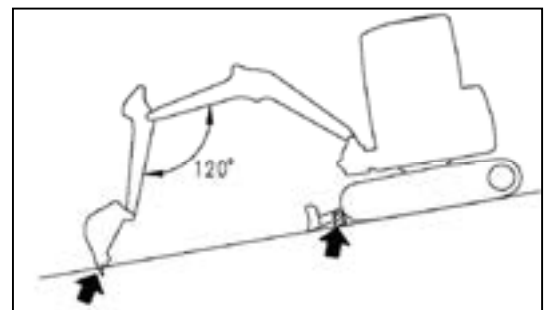

Transport

Loading and Unloading

When loading or unloading the machine, mistaken operation may bring the hazard of the machine tipping over or falling, so particular care is necessary. Always do as follows.

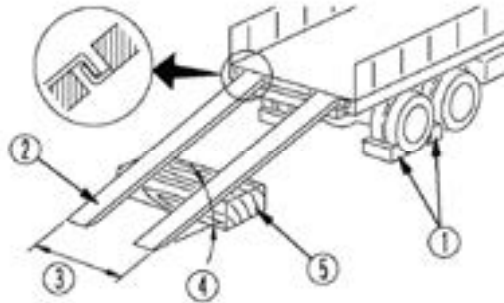

①Stoppers ②Ramp ③Spacing of ramp ④The ramp angle is under 15° ⑤Blocks

- Choose a solid and flat ground and keep a safe distance from the shoulders and edges of the road. Never use working devices to load and unload machines. Otherwise, there is a danger of the machine tipping or falling.
- Always use ramps of adequate strength. Be sure that the ramps are wide, long, and thick enough to provide a safe loading slope. Take suitable steps to prevent the ramps from moving out of position or coming off. Be sure the ramp surface is clean and free of grease, oil, ice and loose materials. Remove dirt from machine-tracks. On a rainy day, in particular, be extremely careful since the ramp surface is slippery.
- Run the engine at low speed and travel slowly.
- Never correct your steering on the ramps. If necessary, drive off the ramps, correct the direction, then enter the ramps again.
- When on the ramps, do not operate any lever except for the travel lever.
- The center of gravity of the machine will change suddenly at the joint between the ramps and the track or trailer, and there is danger of the machine losing its balance. Travel slowly over this point.
- When loading or unloading to an embankment or platform, make sure that it has suitable width, strength, and grade.
- When swinging the upper structure on the trailer, the trailer is unstable, so pull in the work equipment and swing slowly.
- Refer to "Transportation".

Shipping the Machine

When shipping the machine on a trailer, do as follows.

- The weight, transportation height, and overall length of the machine differ according to the work equipment, so be sure to confirm the dimensions.
- When passing over bridges or structures on private land, check first that the structure is strong enough to support the weight of the machine. When traveling on public roads, check first with the relevant authorities and follow their instructions.
- For details of the procedure when transporting the machine, see "Transportation".

Battery

Put the Battery cut-off Switch OFF (closed)

For the following occasions, puts starting switch OFF (closed) position, put the battery cut-off switch OFF (closed) position. Otherwise may cause electric shock and other major accidents.

- Long term storage machine (more than one month);
- When repairing the electrical system;
- When welding;
- When handling the battery;
- When replacing fuses and other parts.

Battery Safety Operation

□ Electricity

- When battery positive and negative electrodes on both ends of a column by metal conductor (such as: metal tools, metal wire, metal parts, etc.) accident nipple, namely external battery short circuit, can produce arc melting polar column, and cause the molten lead alloy splash, serious when the combustion caused a lot of heat.
- Prevention: battery assembly fault diagnosis using metal tools or use metal wire, avoid direct short circuit battery is negative column.
- Protection: wear protective glasses and gloves.
- Emergency treatment: when burning, use live wrench or other tools, external short-circuit metal conductor, immediately disconnect the battery don't contact with, and use the extinguishing fire materials.

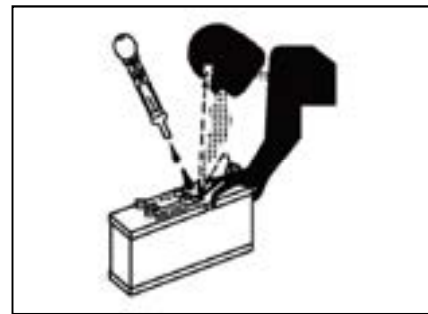

□ Sulfuric Acid

- Filling battery or a battery charging, resulting in shell burst, from sulphuric acid may break out or spills.
- Prevention: careful handling. Vertical placement; According to the supplementary electrical program to supplement the electricity.
- Protection: wear protective glasses and acid proof clothes.
- Emergency treatment: when skin contact with sulfuric acid, immediately flush skin with plenty of clean flowing water surface, and remove contaminated clothes; When the eyes contact with sulfuric acid, rinse immediately with clean water for at least 10 minutes; When due to accidentally splashed acid in the mouth, can drink lots of water or milk. To find a doctor when necessary.

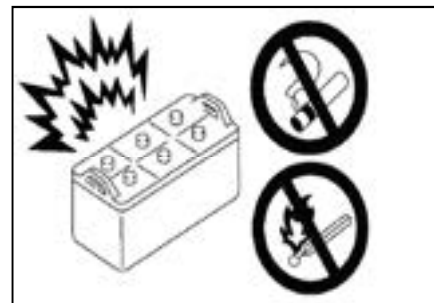

□ Emissions of Gases

- In rechargeable battery, test process, the mixture of hydrogen and oxygen from the induction in vent. If more than 4% hydrogen concentration in the environment, have open flame, sparks or high fever will be an explosion.
- Prevention: charging keep ventilation. Smoking is prohibited, to prevent sparks and open flame. Battery wire connection order: first the positive line connection, after connect the cathode lines; Disconnect the battery cable order: first to disconnect the battery negative electrode wire, and then disconnect the battery positive electrode line.
- Protection: wear protective glasses and acid proof clothes.

- Emergency treatment: battery burst, a large number of spills, sulfate operator should immediately flush sulfuric acid splash down; When necessary, will be ablation of sulfate personnel immediately to a hospital treatment.

Additional Electric Battery

Before cars started, the car with electric start time is too long and abnormal use, because of leakage and long car stops, the vehicle or the vehicle charging generator failure, the battery can't normal charging battery loss caused by electricity, battery electric eye blackened, even can't start the car. The battery need to supplement by electricity.

Check that the open circuit voltage of the battery terminal is lower than 12.45V, and the battery should be supplemented immediately.

□ When charging the battery we must know

- Wearing glasses.
- Maintain environmental ventilation when charging, charging under normal temperature.
- No smoking when charging, and to avoid the introduction of the flame.
- After charging connection, first connect the positive attachment; Take out stitches before charging, disconnect the cathode attachment first.

Battery supplement electricity at action part "Battery Discharges and Charges".

Starting Engine with Booster Cables

If any mistake is made in the method of connecting the booster cables, it may cause the battery to explode, so always do as follows.

- When starting with a booster cable, carry out the starting operation with two workers (one worker sitting in the operator's seat and the other working with the battery).
- When starting from another machine, do not allow the two machines to touch.
- When connecting the booster cables, turn the starting switch OFF for both the normal machine and problem machine. There is a hazard that the machine will move when the power is connected.
- Be sure to connect the positive (+) cable first when installing the booster cables. Disconnect the negative (-) cable (ground side) first when removing them.
- When connecting the auxiliary cable, set the start switch of the faulty machine, the battery disconnect switch and the start switch of the normal machine to the OFF (closed) position. For details, please refer to the item "Battery disconnect switch". When the power is connected, the machine may start and cause danger.
- When removing the booster cables, be careful not to let the booster cable clips touch each other or to let the clips touch the machine.
- Always wear safety goggles and rubber gloves when starting the engine with booster cables.
- When connecting a normal machine to a problem machine with booster cables, always use a normal machine with the same battery voltage as the problem machine.
- For details of the starting procedure when using booster cables, see "Starting Engine with Booster Cables" in the OPERATION section.

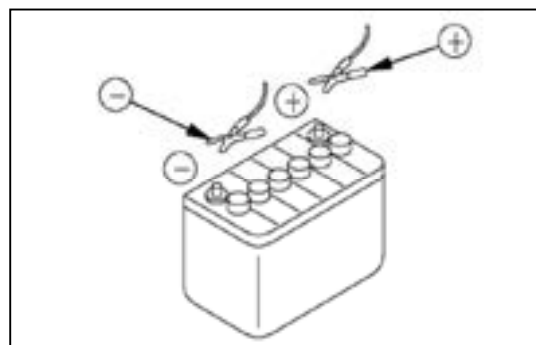
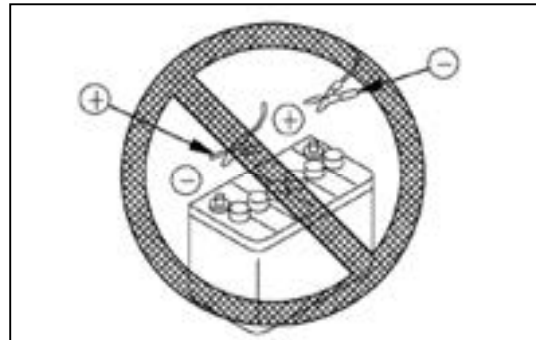

Towing

Safety Rules for Towing

Serious injury or death could result if a disabled machine is towed incorrectly or if there is a mistake in the selection or inspection of the wire rope. For towing, see “Towing the Machine” in the OPERATION section.

- Always wear leather gloves when handling wire rope.
- Fix the wire rope to the frame of the crawler frame (allow two holes at A for traction)
- During the towing operation, never stand between the towing machine and the machine being towed.
- Never tow a machine on a slope.

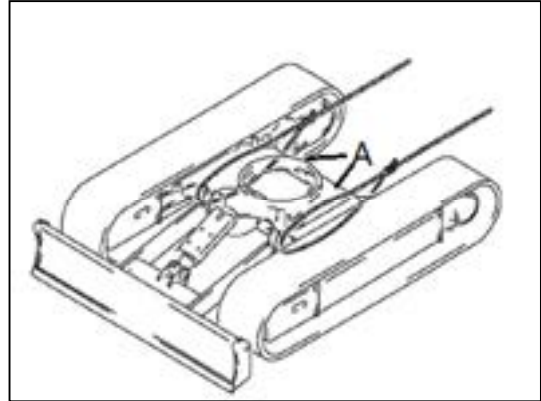

- Never use a wire rope which has cut strands (A), reduced diameter (B), or kinks (C). There is danger that the rope may break during the towing operation.

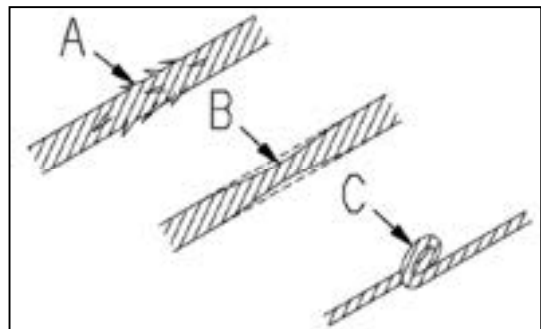

Lifting Work

Safety Rules for Lifting Objects

- Do not carry out lifting work on slopes, soft ground, or other places where the machine is not stable.
- Use wire rope that conforms to the specified standard.
- Do not exceed the specified lifting load.
- For details of the maximum lifting load permitted for this machine, see “Bucket with hook”.
- It is dangerous if the load hits any worker or structure. Always check carefully that the surrounding area is safe before swinging or turning the machine.
- Do not start, swing, or stop the machine suddenly. There is a hazard that the lifted load will swing.
- Don't use two machines together to lift, it is very dangerous.
- Do not use the work equipment or swing to pull the load in any direction. There is danger that the hook may break and the load come off, causing the work equipment to move suddenly and cause personal injury.

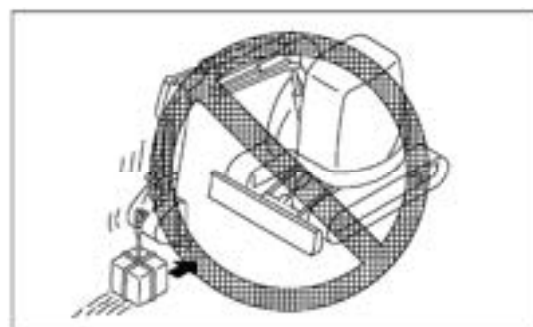

- Do not leave the operator's seat when there is a raised load.

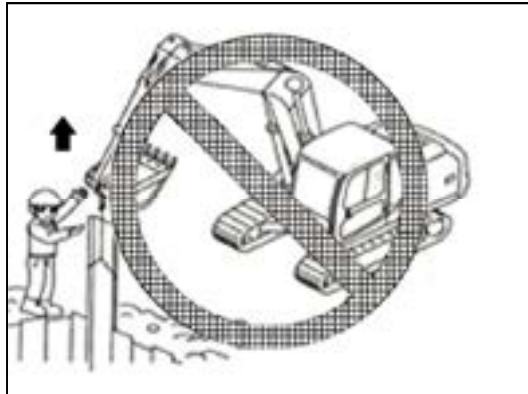

- Do not pull pile.

Safety Maintenance Information

Warning Tag

- Always attach the "DO NOT OPERATE" warning tag to the work equipment control lever. Attach additional warning tags around the machine if necessary.
- Keep this warning tag in the tool box while it is not used. If there is not the tool box, keep the tag in the operation manual pocket.
- If others start the engine, or touch or operate the work equipment control lever while you are performing service or maintenance, you could suffer serious injury or property damage.



Keep Work Place Clean and Tidy

- Choose a flat and solid place.
- Choose a place where there is no danger of landslides, falling rocks or being flooded.
- Make the working device and the bulldozer fully contact the ground.

Appoint Leader When Working with Others

When repairing the machine or when removing and installing the work equipment, appoint a leader and follow his instructions during the operation.

When working with other people, if the meaning is conveyed incorrectly between the workers, it will cause accidents.

Turn off the Engine before Checking and Maintenance

- Park the machine on firm, level ground.
- Select a place where there is no hazard of falling rocks or landslides, or of flooding if the land is low.
- Lower the work equipment and Bulldozer completely to the ground.
- Check that the battery relay is off and main power is not conducted. (Wait for approx one minute after turning off the engine starting switch key and press the horn switch. If the horn does not sound, it is not activated.)

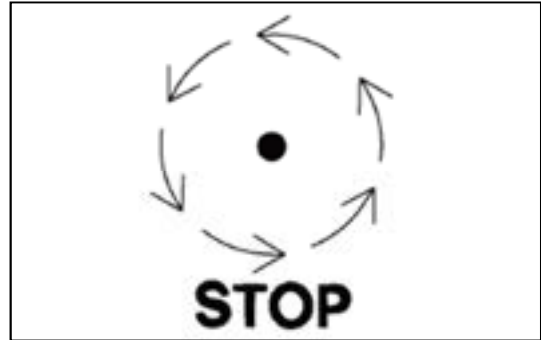

- Push up the work equipment control lever to middle position and push up lock lever to the LOCK position, then turn off the engine.

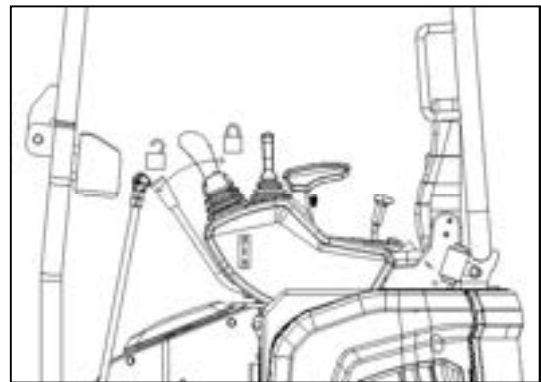

- Put blocks under the track to prevent the machine from moving.

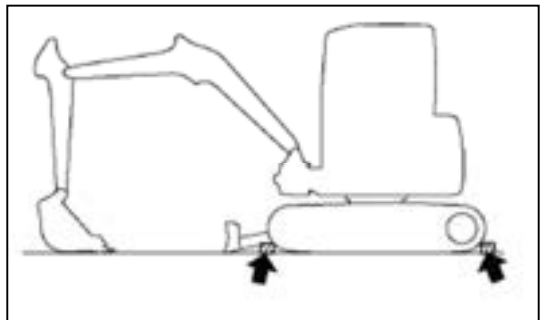

Two workers for maintenance when engine is running

To prevent injury, do not carry out maintenance with the engine running. If maintenance must be carried out with the engine running, carry out the operation with at least two workers and do as follows.

- One worker must always sit in the operator's seat and be ready to stop the engine at any time. All workers must maintain contact with the other workers.
- Set lock lever to the LOCK position.

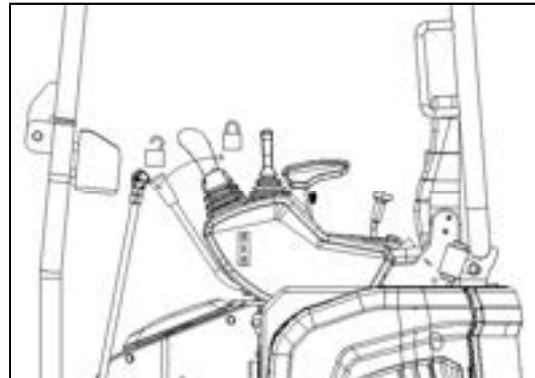

- When carrying out operations near the fan, fan belt, or other rotating parts, there is a hazard of being caught in the parts, so be careful not to come close.
- Do not touch any control levers. If any control lever must be operated, give a signal to the other workers to warn them to move to a safe place.
- Never drop or insert tools or other objects into the fan or fan belt. Parts may break or be sent flying.



Proper tools

Use only tools suited to the task and be sure to use the tools correctly. Using damaged, low quality, faulty, makeshift tools or improper use of the tools could cause serious personal injury.

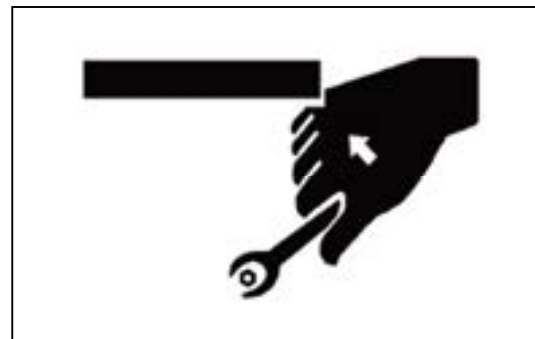

Personnel

Only authorized personnel can service and repair the machine. Do not allow unauthorized personnel into the area. If necessary, employ an observer.

Attachment

- Appoint a leader before starting removal or installation operations for attachments.
- Place attachments that have been removed from the machine in a stable condition so that they do not fall. And take steps to prevent unauthorized persons from entering the storage area.

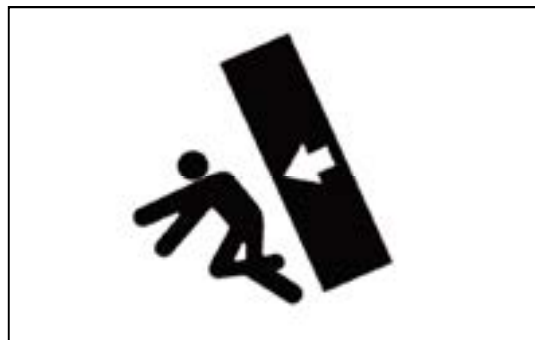

Work under the machine

- If it is necessary to go under the work equipment or the machine to carry out service and maintenance, support the work equipment and machine securely with blocks and stands strong enough to support the weight of the work equipment and machine.
- It is extremely dangerous to work under the machine if the track shoes are lifted off the ground and the machine is supported only with the work equipment. If any of the control levers is touched by accident, or there is damage occurring to the hydraulic piping, the work equipment or the machine will suddenly drop. This is extremely dangerous. Never work under the work equipment or the machine.



Noise

When carrying out maintenance of the engine and you are exposed to noise for long periods of time, wear ear covers or ear plugs while working. If the noise from the machine is too loud, it may cause temporary or permanent hearing problems.

hammer

When using a hammer, pins may fly out or metal particles may be scattered. This may lead to serious injury. Always do as follows.

- If you use a hammer to hit hard metal parts, such as pins, bucket teeth, cutting edges or bearings, there will be fragments scattered and will cause a serious personal accident. Be sure to wear protective equipment such as goggles and gloves.
- When knocking on the pin or bucket teeth, there may be a danger of fragments flying out, which may cause injury to people in the surrounding area. Make sure that there are no people in the surrounding area.
- If you strike the pin with a strong force, there may be a danger of the pin flying out, which may cause injury to people in the surrounding area.

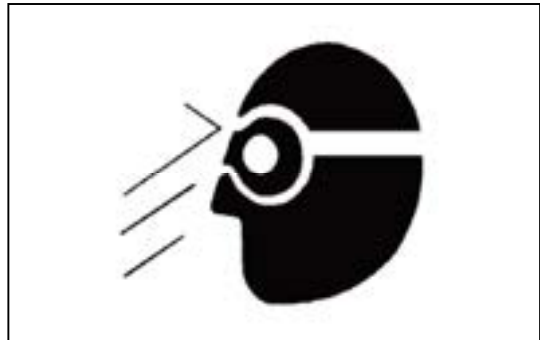

Welding works

Welding operations must always be carried out by a qualified welder and in a place equipped with proper equipment. There is a hazard of gas, fire, or electrocution when carrying out welding, so never allow any unqualified personnel to carry out welding.

Removing battery terminals

When repairing the electrical system or when carrying out electrical welding, remove the negative (-) terminal of the battery to prevent the flow of current.

Safety first when using high-pressure grease to adjust track tension

- Grease is pumped into the track tension adjustment system under high pressure. If the specified procedure for maintenance is not followed when making adjustment, grease drain plug (1) may fly out and cause serious injury or property damage.

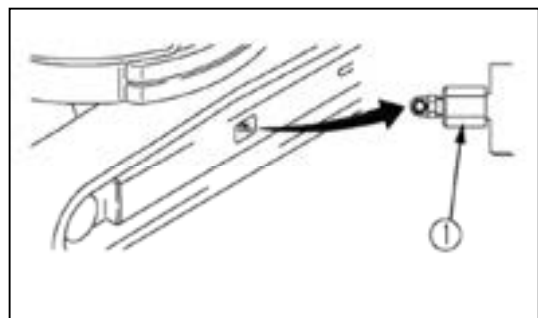

- When loosening grease drain plug (1) to loosen the track tension, never loosen it more than one turn. Loosen the grease drain plug slowly.
- Do not place the face, hands, feet or other parts of the body close to the grease drain plug①.

Do not disassemble recoil springs

Never attempt to disassemble the recoils spring assembly. It contains a spring under high pressure which serves as a shock absorber for the idler. If it is disassembled by mistake, the spring will fly out and cause serious injury. When it becomes necessary to disassemble it, ask your CFG distributor to do the work.



High pressure oil

Hydraulic system is stressful. When inspecting or replacing the pipe or hose, be sure to check the pressure inside the hydraulic circuit has been released, otherwise, it will cause major accidents. So do as the following provisions:

- Release the pressure. When the hydraulic system has pressure, don't inspect and replace the operation.
- If there are any pipe or hose leaks, or its surrounding area is wet, check whether the pipe or hose burst, and whether the hose expansion. Wear protective equipment such as goggles and leather gloves, when check.
- High pressure oil from the hole leakage will penetrate into the skin, if it contact with eyes direction, you will be at the risk of blindness. If skin or eyes was hit by a high pressure oil, Rinse with clean water and contact the doctor immediately.



Operation of the pipeline and high pressure hose

If high pressure hose or pipeline leak, it will cause a fire or the operation failure, lead to major accidents. If you find the hose leaks or the installation of piping parts loose, stop working and tighten the installation site to specified torque again. If there is any damage on hose or piping or deformation, contact with the CFG distributor.

The hose should be replaced, if existence as follows:

- Hose damage, pipe joint deformation, o-ring damage.
- Cladding torn or broken, or reinforcing steel wire exposed.
- Clad inflation in some places.
- Movable part of the hose distorted or signs of a crush.
- Cladding with foreign matter.



Waste materials

To prevent pollution, pay careful attention to the method of disposing of waste materials.

- Always put oil drained from your machine in containers. Never drain oil directly onto the ground or dump into the sewage system, rivers, the sea, or lakes.
- Obey appropriate laws and regulations when disposing of harmful objects such as oil, fuel, coolant, solvent, filters, and batteries.

Compressed air

- When carrying out cleaning with compressed air, there is a hazard of serious injury caused by flying particles.
- When using compressed air to clean elements or the radiator, always wear safety goggles, dust mask, gloves, and other protective equipment.

Periodic replacement of safety critical parts

- For using the machine safely for an extended period of time, replace safety-critical parts like hoses and seat belts periodically. Replacement of safety-critical parts: See “Safety Critical Parts”.
- The material of these components naturally changes over time, and repeated use causes deterioration, wear, and fatigue. As a result, there is a hazard that these components may fail and cause serious injury or death. It is difficult to judge the remaining life of these components from external inspection or the feeling when operating, so always replace them at the specified interval.
- Replace or repair safety-critical parts if any defect is found, even when they have not reached the time specified interval.

便签页

OPERATION

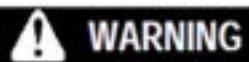

Before reading this chapter, please read and understand the security component.

General Drawing of Control Device

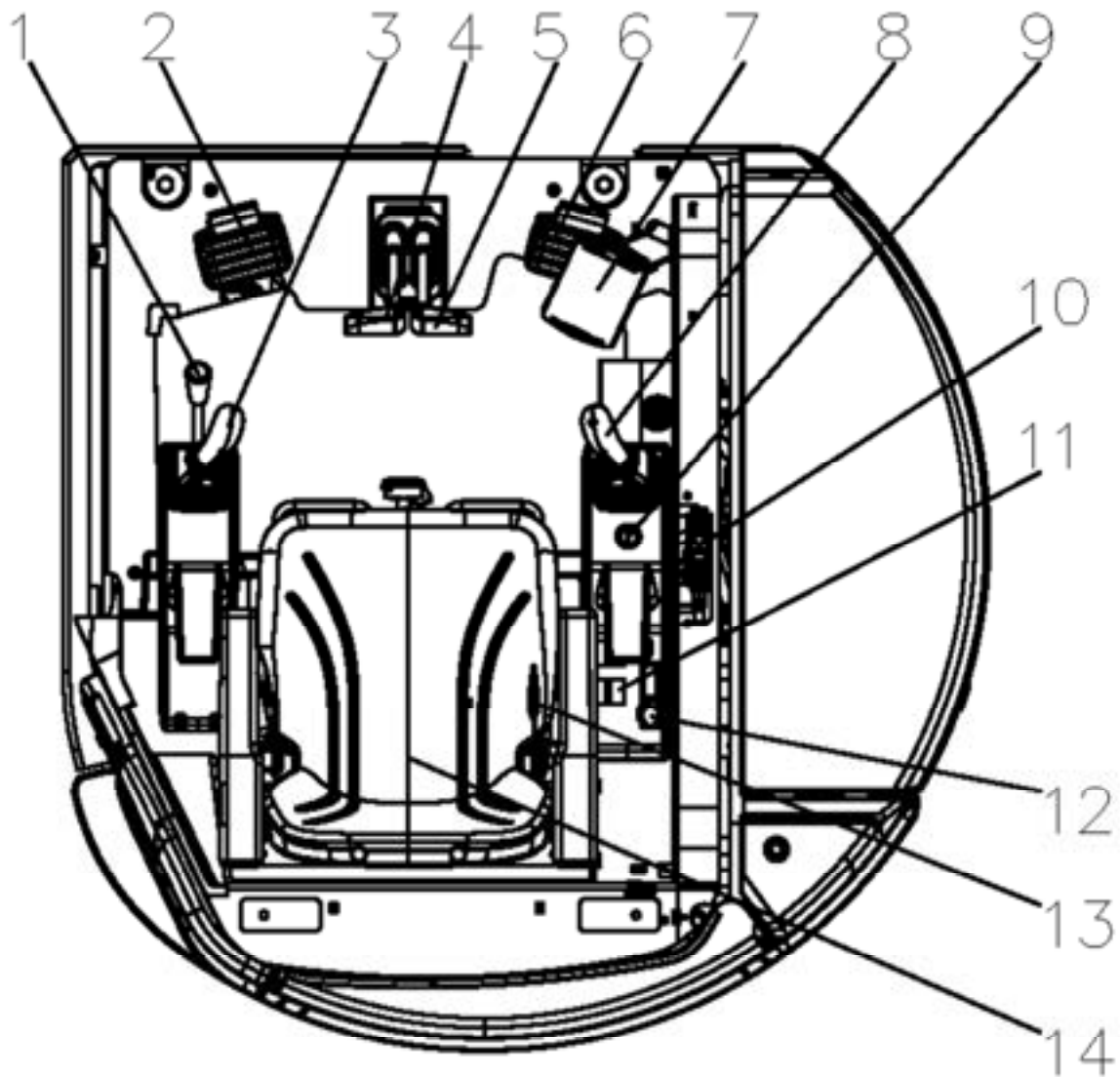

- | | |
|---------------------------------|----------------------------------|
| 1. Security lock lever | 8. Right working device joystick |
| 2. Auxiliary pipeline control | 9. Electric lock |
| 3. Left working device joystick | 10. Bulldozer control handle |
| 4. Left walking joystick | 11. Shift switch |
| 5. Right walking joystick | 12. Throttle joystick |
| 6. Boom side swing control | 13. Seat belt |
| 7. Monitor | 14. Seat |

Description of Instrument and Control Device

The followings are the descriptions of how to operate the devices on the machine. In order to operate the devices correctly and safety, you shall understand the operation method and the meaning of the display.

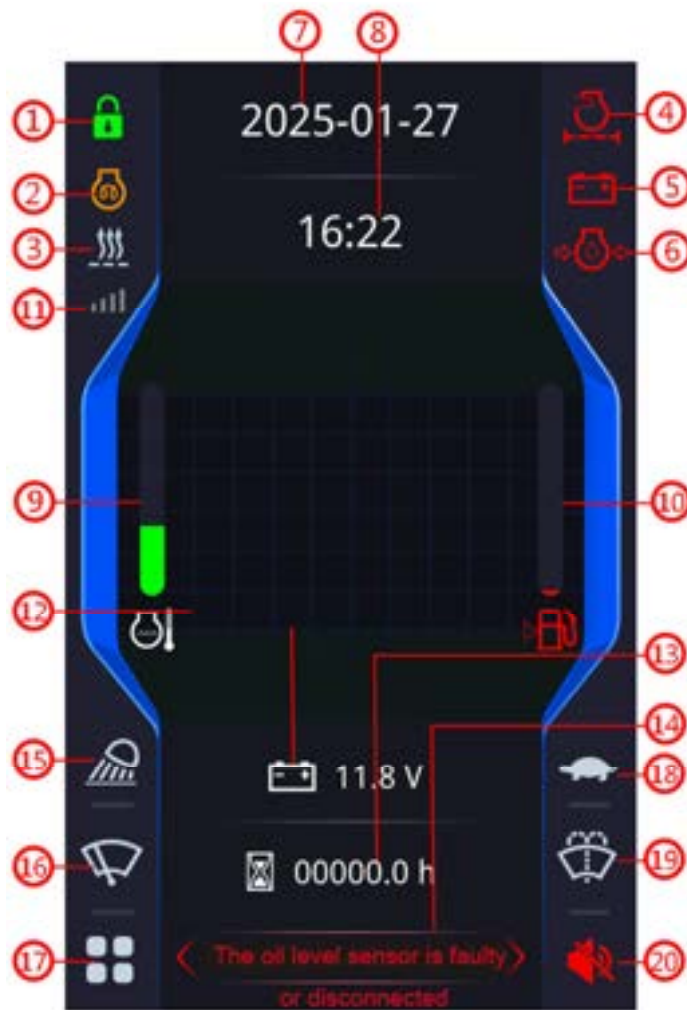

Monitor

Home Screen



- | | |
|-----------------------------------|--------------------------------|
| 1. Pilot switch indication | 11. Engine speed indication |
| 2. Preheating signal indication | 12. Battery voltage indication |
| 3. Heater status indication | 13. Working hour indication |
| 4. Air filter blocking alarm | 14. Fault alarm text display |
| 5. Charge alarm | 15. Working light switch |
| 6. Oil pressure alarm | 16. Wiper switch |
| 7. Beijing time and date display | 17. Menu key |
| 8. Beijing time time display | 18. High and low speed switch |
| 9. Cooling temperature indication | 19. Wiper water jet switch |
| 10. Fuel level indication | 20. Buzzer mute button |



1. Pilot Switch Indication

According to the machine pilot safety lock state for the corresponding indications, display  when pilot lock is pulled up and  when pilot lock is lowered.

2. Preheating Signal Indication

According to the machine preheating state for corresponding instructions,  is displayed when the machine is in preheating, and the icon is not displayed when it is not in preheating.

3. Air Conditioning System Switch

Operate the machine air conditioning system switch according to the demand and give corresponding instructions,  is displayed when the air conditioning system is on and  is displayed when it is off .

4. Air Filter Blocking Alarm

Give corresponding instructions according to the alarm state of air filter blockage, when the air filter is blocked ,  is displayed, when no air filter is blocked, the icon is not displayed.

5. Charge Alarm

Give corresponding instructions according to the charging alarm state,  is displayed when there is a charging alarm, and the icon is not displayed when there is no charging alarm.

6. Oil Pressure Alarm

According to the oil pressure alarm state for corresponding instructions,  is displayed when there is oil pressure alarm, and the icon is not displayed when there is no oil pressure alarm.

7. Beijing Time And Date Display

According to the set local Beijing time, display the information of the year, month and day.

8. Beijing Time Display

According to the set local Beijing time, displays the time, minute and second information.

9. Cooling Temperature Indication

According to the machine current cooling water temperature indication, can set the display range of 35°C-140°C.

10. Fuel Level Indication

According to the machine current fuel level percentage indication, can set the display range of 0%-100%.

11. Engine Speed Indication

According to the machine current engine speed indication, can set the display range of 0rpm-3000rpm.

12. Battery Voltage Indication

According to the machine current battery voltage value indication, accurate to 0.1V.

13. Working Hour Indication

When the machine starts the timing, icon  changes dynamically, and icon  remains unchanged after the timing stops.

14. Fault Alarm Text Display

When there is no fault in the machine, display:

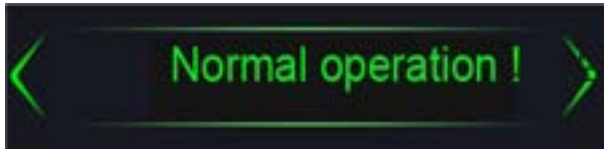



When the machine has a fault, the corresponding fault text is displayed, such as:



If multiple faults exist, the system displays them in turn.

15. Working Light Switch

The default working light on the machine is off, at this time, the working light switch display .

Press the work light switch, the work light switch will display , indicating that the work light is on. Continue to press the work light switch, the work light switch back to the off state.

16. Wiper Switch

The default wiper switch on the machine is off, at this time, the wiper switch displays .

Press the wiper switch and the wiper switch will show , indicating that the wiper is in action. Continue to press the wiper switch, the wiper switch will return to the off state.

17. Menu Key

Home screen press the menu button to display the main menu page.

Main menu page press the menu button to return to the main screen.



18. High And Low Speed Switch

By default, the high/low speed switch is low speed, in this time,  is displayed on the high/low speed switch. Press the high and low speed switch, and the high and low speed switch will display



, indicating that the machine is switched to high speed. Continue to press the high and low speed switch, high and low speed switch back to the low speed state.

19. Wiper Water Jet Switch

The default wiper water switch on the machine is off, at this time, the wiper water switch displays . Press the wiper water switch, if the wiper water keeps spraying and  is displayed, the wiper is spraying. Continue to press the wiper water switch, the wiper water switch back to the off state.

20. Buzzer mute button

When the instrument buzzer does not sound, the buzzer muffler key is displayed as , pressing the buzzer has no effect.

When the instrument buzzer buzzes, the buzzer muffler key is displayed as , pressing the

buzzer key to muffle the sound of the instrument buzzer, after the muffler,  is displayed. Press the buzzer mute button again, and the buzzer will return to the buzzer state.

Main menu



Main menu	Usage information	Operational information
		Machine information
		Instrument information
	User settings	Brightness setting
		Language setting
		Clock setting
		Login password change
	System setting (88888888)	Control parameter setting
		Machine information setting
		Restore default parameters

1. Usage information

It mainly contains some information pages for users to consult, for users to consult some key information. Contains operation information, GPS information, machine information and instrument information menu:



1.1 Operational information

One page of operating parameters for users to refer to:



Contain engine speed, cooling water temperature, system voltage, fuel level and operating hours. Users can check the changes of parameters in real time and master the changes of parameters in real time and master the running sate of the vehicle.

In addition to the above basic parameter displays, there are also parameter pages for debugging use. Language Click the parameter display area on the touch screen, and the password input page will pop up:



After you enter the password 432109 on the touch keyboard, you can view the following information on the running information page:

1.2 Machine information

Displays the current machine number and service number:



1.3 Instrument information

Displays the current meter chart number and software version:



2. User settings

Contains basic settings for users, including brightness settings, language settings, clock adjustment and login password change menu:

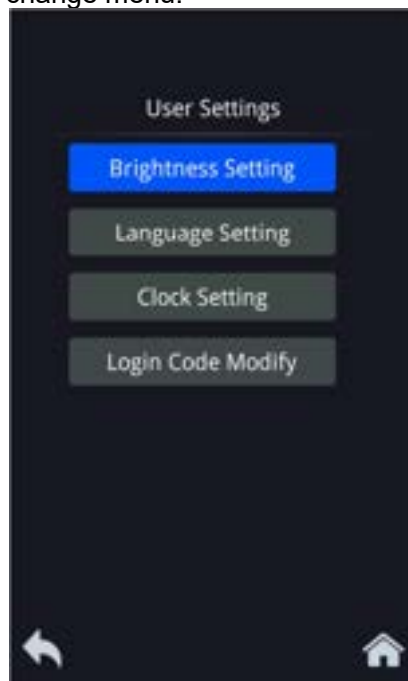

2.1 Brightness setting

For the user to set the current display brightness of the instrument, the page is as follows:

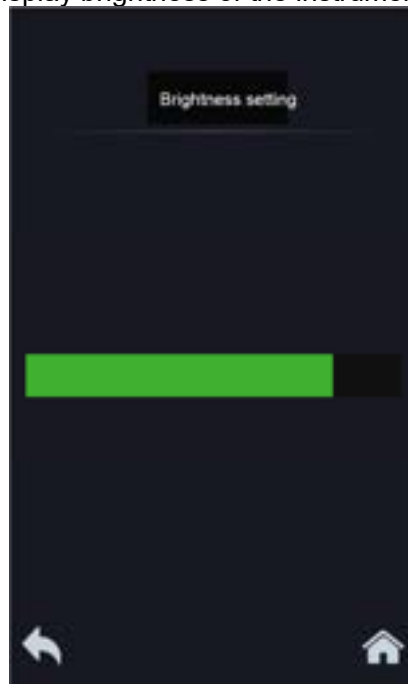

Touch the brightness display area with your finger and drag your finger to adjust the brightness to an appropriate.

2.2 Language setting

The system language for users to set the instrument is supported in multiple languages, the page is as follows:



2.3 Clock setting

For users to set Beijing time usage, the page is as follows:



2.4 Login password change

This parameter is used to set a personal login password, when all zeros are set, the login password function is cleared and machine can be started without password verification. If the login password is not set to 0, the user must enter the correct password before starting the machine.

The login password change page is as follows:



You can set a new password only after you enter the correct old password. If you enter an incorrect old password, a message page is displayed.

If you enter the same password twice, the following prompt page is displayed:

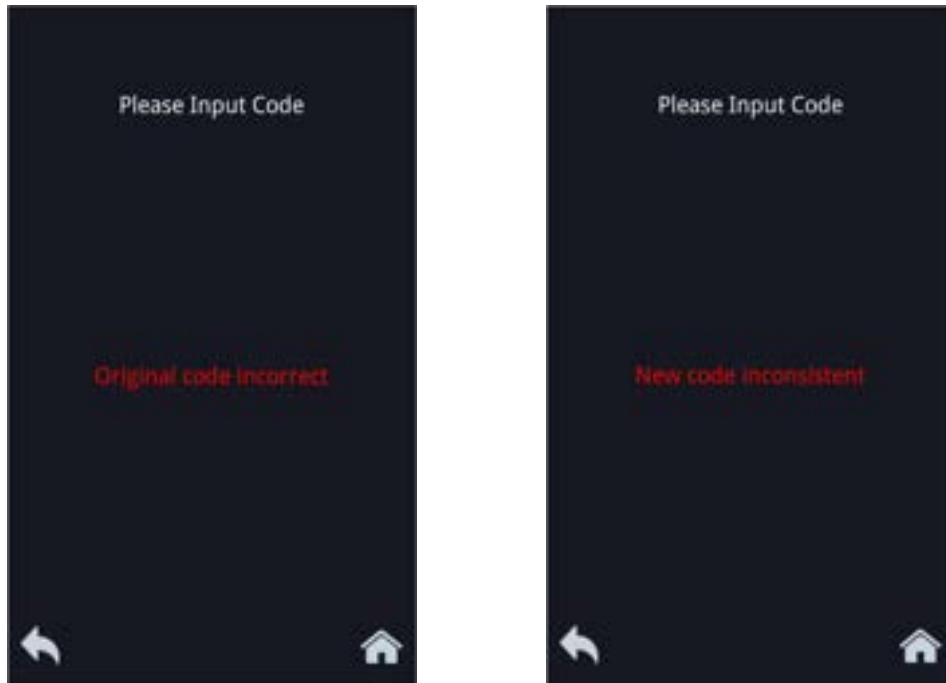

3. System setting

For professionals to set some key parameters, including control parameter settings, machine information settings and restore default parameter menu page:



Star the engine normally

When the start switch is turned to the ON position, the main screen is displayed.

Normally shut down the engine

The display will turn off when the start switch is turned to the OFF position.

An exception occurs when starting the engine or during operation

When an exception occurs, the alarm icon will display the corresponding alarm warning according to the type of the exception.

Alarm prompt

When the engine is running always pay attention to various lalm ICONS or prompts in the main interface. When there is a fault, the corresponding alarm icon will be lit up, or the text will prompt the fault information.

Trouble Shooting and Investigation

The monitor displays the working state, and also detects the engine lubrication system, cooling system, air intake system and power generation system at the same time.

1. High coolant temperature alarm: It indicates that the coolant temperature is above the setting value. When it is warning, must check the cooling system whether lack of the coolant, whether it is leakage, or check the actual temperature of the tank is too high, the coolant temperature sensor is in short circuit.
2. Low oil pressure alarm: investigate from the following aspects
 - Engine oil filter is dirty or not.
 - Engine oil pump is working properly or not.
 - The engine oil is lack or not.
3. High hydraulic oil pressure alarm (only for models equipped with hydraulic oil pressure sensor), the main pump pressure of the hydraulic system is higher than the set pressure, mainly from the following aspects.
 - Check that the main relief valve of the main valve is functioning properly or not.
 - If not, please contact the nearest dealer to ask for help.

WARNING

Once the alarm signal is displayed, it should stop the machine immediately. Otherwise, the engine speed will reduce to idle speed after the setting time, and record the fault time.

4. Low coolant level alarm (only for models equipped with coolant pressure sensor): indicates that the coolant level in the cooling system is lower than the safe value, and should be checked at this time:
 - The coolant level is below the low level or not.
 - Whether the radiator lacks coolant, the radiator and the seal are leaking or not.
5. Low fuel oil level: The amount of the fuel (less than 10% of the oil in the fuel tank) in the tank should be checked and the fuel should be added in time.
6. Air filter clog alarm (only for models equipped with air filter clogging sensor): It indicates that the main filter element of the air cleaner is dirty, and it should be cleaned or replaced timely.
7. Charging alarm: indicates that the battery charging is abnormal. When the engine is started, the generator charges the battery abnormally.

IMPORTANT

The above picture is used for operation reference, if it does not match, to prevail in kind.

Specific text and sequence of operations may change due to system upgrades, without notice.

Other Control Devices

1. Speaker switch

When press the button on the top of the left control level, the speaker will sound.

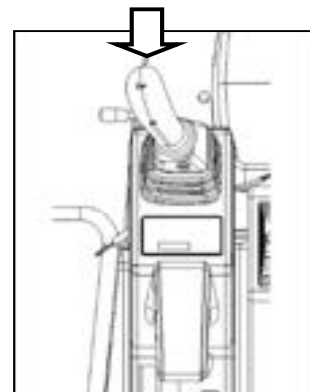

Speaker function-check

1. Turn the key switch to the ON position.
2. Confirm that the speaker will sound when the speaker button on the right handle is pressed. If the speaker does not work, please contact CFG dealer for repair.

2. Start switch

The switch is used to start or shut down the engine.

- OFF position

The key can be inserted or removed. All switches of the electrical system are closed and the engine is stopped.

- ON position

Current flows in the charging and lamp circuits. When the engine is running, keep the starter key in the ON position.

- START position

This is the engine start position. When starting the engine, keep the key in this position. After the engine starts, release the key immediately and it will automatically return to the ON position.

- HEAT (preheat) position (only for models with manual preheating, this model has automatic preheating)

When starting the engine in winter, you must first turn the key to this position. The preheating time does not exceed 15s, and the preheating will be automatically disconnected if it exceeds 15s. After preheating, release the key immediately and it will automatically return to the OFF position.



3. Lock lever



- When leaving the operator's seat, set the lock lever securely to the LOCK position. If the lock lever is not at the lock position, and the control levers are touched by mistake, it may lead to serious personal injury.
- If the lock lever is not securely at the LOCK position, the lock lever may be moved, it may lead to serious accident or injury.
- When pulling the lock lever up, be careful not to touch the work equipment control lever.
- When pushing the lock lever down, be careful not to touch the work equipment control lever.

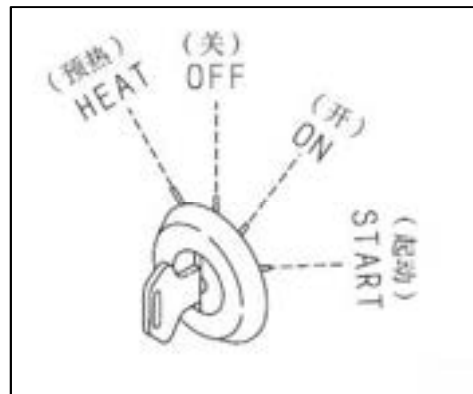

This lever is a device to lock the work equipment, swing, travel, and attachment (if equipped) control levers.

- LOCK position: The engine can be safely started or the operation can be stopped.
- FREE position: The excavator is allowed to operate normally.



Notice: This lock lever is of hydraulic lock type. Accordingly, when it is in the lock position, the control levers or control pedals move but the machine does not move.

Notice

- When the lock lever is at the LOCK position, allow to start the engine only, otherwise it can not work.
- The lock lever is at the FREE position, if the engine stops, set the lock lever to the LOCK position, then start the engine again.

4. Throttle knob

This knob is used to control engine speed and output power.

-  For the low speed position: push forward to reduce engine speed and power.
-  For the high speed position: Pull back to increase engine speed and power.

5. Working device control handle



WARNING

- Operation mode is set to standard mode (ISO mode)
- When you need to change the mode of operation, please contact the dealer.
- When changing the mode of operation, please replace operation signs to ensure consistent with the operation of the machine.

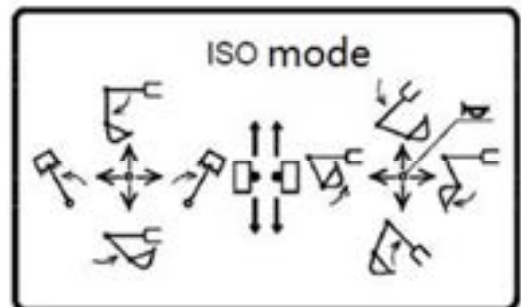

Left work equipment control lever is used to turn and operate the arm.

- 1 Arm OUT
- 2 Arm IN
- 3 Swing to LEFT
- 4 Swing to RIGHT
-

Right work equipment control lever is used to operate the boom and bucket.

- 1 Boom LOWER
- 2 Boom RAISE
- 3 Bucket DUMP
- 4 Bucket CURL

Middle: The upper body and stick, boom and bucket remain in place.

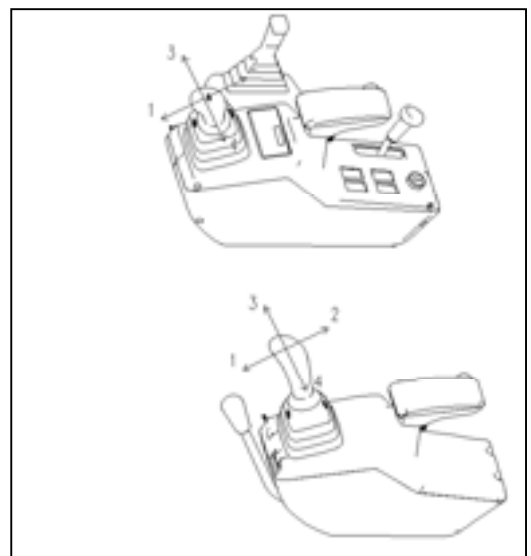

6. Travel levers

WARNING

- Do not rest your foot on the pedal during operations.
- When operating the walking handle/pedal (Optional), determine the walking direction of the crawler.
- The following description is for when the driving wheel is at the rear and the driving wheel is at the front, the walking operation sequence is reversed.

This lever is used to change the direction of travel between forward and reverse.

- Operating 1,3 simultaneously: retrogression.
- Operating 2,4 simultaneously: forward.
- Separate operation 4 or 1: turn right
- Separate operation 2 or 3: turn left
- Operating 1 or 4 simultaneously: turn right around
- Operating 2 or 3 simultaneously: turn left around
- When the lever return to the middle position, the machine stops.

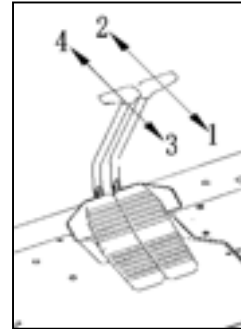

Equipment Lock

The engine cover is equipped with the lock. A key is required to open and lock these locks.

NOTICE

Insert the key the end, then turn the key clockwise. If the key is turned before it is inserted all the way, it may break.

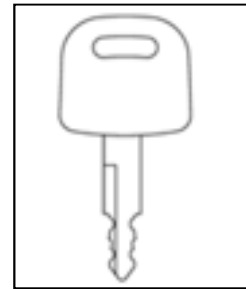

Engine hood lock

There are three positions of the lock here. When the key is turned or released later, the key will automatically spring back to the middle position following the lock cylinder.

Ⓑ Opening the Lock

Insert the key into the key slot. Turn the key clockwise, then open the lock.

Ⓐ Locking the Lock

Insert the key into the key slot. Turn the key anticlockwise, then lock it.

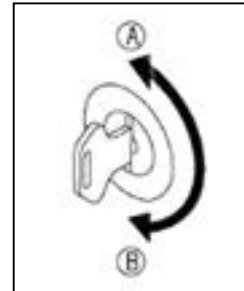

Battery Disconnect Switch

IMPORTANT

In addition to the following cases, this switch should be in the I (electrify) position,

- Long term storage machine (more than one month)
- When repairing the electrical system
- When welding
- When handling the battery

If you switch to the O (OFF) position, all electrical systems are

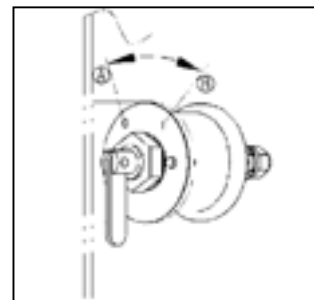

switched off. This switch is used to cut off the current from the battery. Located in the machine right cover, you can see it when open the foot pad.

A: O, (Off) position

B: I, (Electrify) position

Before operating the machine, always place the switch in position I.

Fuse

The machine is equipped with a central controller, which is installed under the seat. The internal fuse can prevent electrical equipment and wires from burning out. If the fuse box fuse is corroded or white powder can be seen, or the fuse is loose in the fuse holder, replace the fuse.

WARNING

- Before replacing a fuse, be sure to turn off the starting switch.
- Do not install the fuse that is specified on the label, otherwise there is a risk of damage to the circuit board or fire.
- Fuse burn off, must identify the cause of the fault, the party can be replaced.
- After the fuse is blown out, the fuse must be replaced with the same standard.
- When the fuse is corroded, the surface appears white powder or fuse is loose, should check and timely.
- The fused fuse can not be repaired, and should be replaced in a timely manner.

Fuse capacity and electrical name (After opening the fuse box cover, face the fuse box from left to right)

number	fuse capacity	electrical name	number	fuse capacity	electrical name
1	20A	Electric lock	10	10A	Preheating relay
2	10A	Cab lights, clocks	11	30A	Glow plug
3	20A	Monitor	12	30A	starter
4	20A	The cigarette lighter	13	10A	Upper electric signal
5	10A	Solenoid valve	14	30A	Flameout Solenoid valve
6	10A	horn	15	10A	radio
7	10A	Relay	16	20A	Wiper
8	10A	motor	17	10A	Excitation, Oil pump
9	30A	Plateau valve	18	20A	Warm air blower

box Fuse

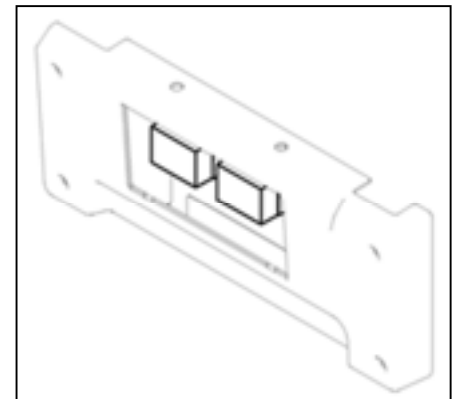

Radio

Instruction



- (1) Please read this manual before use the kit.
- (2) Please keep this manual for reference.
- (3) Kit fuse out of specification is prohibited.
- (4) Speaker impedance must be equal or over 4Ω.
- (5) Keep away from water / dust / magnetic environments to kit.
- (6) The kit out of order please shut down power, then inform our service department.
- (7) The kit without guarantee for self-caused damages.

Features

- FM digital tuning Bluetooth radio function.
- Auto seek, manual seek, to preset store station.
- Bluetooth version 5.0, communication range 10m (open field).
- USB MP3 player.
- USB charging function.
- MP3 scan and quick scan.
- MP3 repeat, random, pause function.
- MP3 music form and play time indication.
- MP3 continuous play from interruption.
- BEEP tone.
- Mute and loudness.
- Volume, treble, bass, balance.
- Clock for 12/24-hour interchange.
- AUX input (optional).
- LCD display.

Control panel







- | | |
|---|--|
| (1) POWER  | Power switch. |
| (2) MUTE | One button mute. |
| (3) MODE | Radio, Bluetooth music (BT), AUX (LINE optional) model switch, answer Bluetooth phone. |
| (4) SEL | Hang up the Bluetooth call and press the clock setting button. |
| (5) SEEK  | Manual/automatic radio search button, select to play MP3 previous/next button. |
| (6) VOL -/+ | The volume adjustment key is used to coordinate with SEL to set the clock. |

Operating instructions

1、 FM radio mode key function description

1.1 Press the POWER key for the first time for about 5s, and then turn it on to enter FM radio mode, press POWER to turn it off.

Short press SEEK  /  to automatically reduce / increase the search step from the current frequency until the station is locked;

Press and hold SEEK  /  to enter the state of manual single-step frequency adjustment, increase or decrease the frequency in 0.1 MHz steps, and wait for about 3 seconds after the operation is completed to automatically return to the automatic mode. That is, short press to automatically search for a radio station, Long press to manually adjust the radio frequency in one step.

1.2 Volume adjustment control in FM radio mode

In FM radio mode, short press the VOL +/- key, and the current volume will only decrease/increase by one level;

Press and hold the VOL +/- key, and the current volume will decrease and increase gradually until the key is released.

1.3 Clock setting in FM radio mode

When the radio is working, short press the SEL key, and the display will switch to display the current time. When the display is in the display time state, the hour number flashes after long pressing the SEL key, at this time, press the VOL +/- key to decrease / increase the hour number; After that, short press SEL key will flash the number of minutes, at this time, press VOL +/- key to decrease / increase the number of minutes to reach the set time. Finally, long press SEL key again or do nothing to save the time setting after 5s.



After setting, the clock will continue to cycle when BAT (yellow line) is not powered on.

2、 Bluetooth operation



2.1 Bluetooth connection operation

When the radio is working, turn on the Bluetooth of the mobile phone and search for the new "device" function. When the system gets the signal contact with the mobile phone "ORTEK_T119" will be displayed on the screen of the mobile phone, and click the pair. After the connection is successful, the small icon  lights up to indicate that the connection is successful. The above operations may vary due to different mobile phones, and the actual operation shall prevail.

2.2 Bluetooth call operation

In any model, when you make a call with your mobile phone, CALL and the dialed phone number will be displayed on the radio screen. You can talk directly to the radio. The call volume can be adjusted by the VOL key. Short press  to end the call. When a call is incoming, the radio screen will display CALL and the incoming phone number. Short press  to answer the call.



2.3 Bluetooth music operation



When you want to listen to songs in your mobile phone through Bluetooth, you must switch to BT mode. You can select the next / previous song by short pressing  /  (must be supported by mobile phone). The song volume can be adjusted by the VOL key.

◆Note: Bluetooth compatibility of all mobile phones cannot be guaranteed.

3、 USB-MP3 play mode key function description

3.1 In the radio working mode, after inserting the USB flash disk, it will automatically switch to the USB flash disk playing mode

Short press SEEK  /  to select the next / previous MP3 song to play;

Press and hold SEEK  /  to rewind and fast forward to play the current song.

3.2 Volume adjustment control in USB-MP3 playback mode

In the USB-MP3 playback mode, short press the VOL +/- key, and the current volume will only

decrease / increase by one level;

Press and hold the VOL +/- key, and the current volume will decrease / increase gradually until the key is released.

4. AUX radio input mode key function description (optional)

4.1 Short press MODE key to switch the mode to AUX audio input mode(optional), and the screen displays LINE.

4.2 In AUX audio input mode, the SEEK key has no effect.

4.3 In the AUX audio input mode, the volume level can be adjusted through the VOL +/- key.

Installation method

Please turn off the power before install the kit, (Below drawing is a standard, customer requirement is specially made).

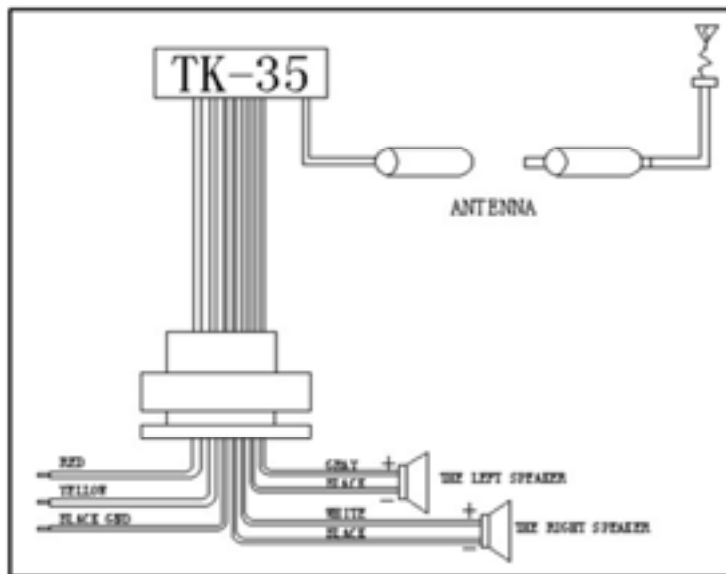

Problems Shooting

Problem	Why and settle methods
No sound	1.Check connection 2. Delete Mute function 3.Increase Volume up 4. Restart
No Display	1. Wrong installation
USB no play	1. USB in correct insertion 2. USB without MP3 format 3. MP3 sizes over 511

Technical specification

■General characteristics

Power supply voltage DC10~32V
 Speaker impedance 4Ω or 8Ω
 Max output power 10W (4Ω) * 2CH 24V standard input

■General tuning (FM)

Frequency range 87.5MHz—108 MHz
 Station search step length: 100KHz (0.1MHz)

Locking sensitivity	23±10 dB
Signal-to-noise ratio	>50 dB
■Bluetooth	
Bluetooth version	5.0
Communication range	10m (open field)
■MP3 part	
Frequency response	20Hz—20KHz
Signal-to-noise ratio	>60 dB

Precautions:

- ◆ If there are any improvement measures for the machine, the technical specifications and design will be changed, and this change will not be prompted in advance.
- ◆ In order to avoid traffic accidents, please put the volume at an appropriate position.
- ◆ In hot or cold weather, please keep the machine in the car. The ideal temperature can ensure the good performance of the machine.
- ◆ This machine is easy to be damaged after being soaked with water. When you want to wash the car, please pay attention not to spray water onto this machine.
- ◆ When the machine is high power output state for a long time, the temperature of its casing will increase significantly. This is a normal phenomenon, don't touch objects that are easy to burn.
- ◆ Non-professional maintenance personnel of our company are not allowed to tear the warranty seal of the machine and disassemble the machine for adjustment and maintenance without authorization, otherwise our company will not provide warranty service.
- ◆ If the user has any questions about this manual, please call so that you can operate the machine correctly.

Air Conditioner System

Statement: At present, the air conditioning system of the standard model is only equipped with heating function, without cooling function.

Control panel

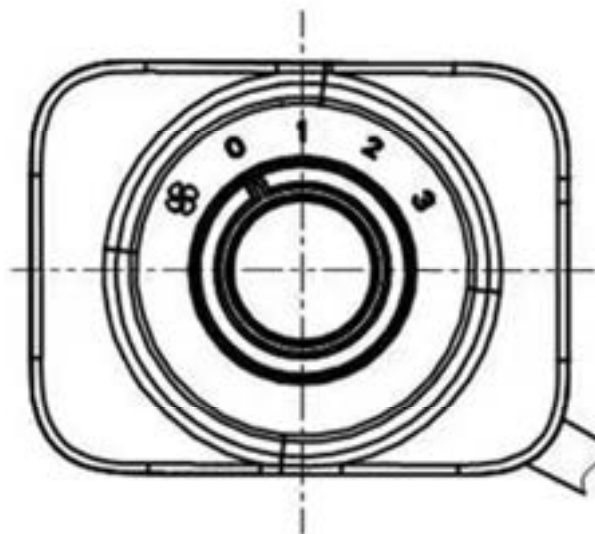



Air volume adjustment switch

Fan Switch

Rotate and adjust the heating air volume (the air flow can be adjusted to 3 levels, 0/1/2/3).

Heating

1. Start engine.
2. Click on the main instrument of the machine to open the air conditioning system.  will be displayed when the air conditioning system is open,  will be displayed when the air conditioning system is closed.
3. Use the air volume adjustment switch to adjust the air volume according to the situation. The air volume increase from gear1 to gear3.
4. After starting to blow hot air, turn the temperature regulating switch (1) clockwise to the end, and turn the air volume regulating switch (3) clockwise to the 3rd gear (HIGH) position, which is helpful to rapidly raise the temperature in the car.
5. When the cab temperature rises to a suitable temperature, the temperature adjusting knob (1) and the air volume adjusting knob (3) can be adjusted to reset the temperature.

Remark: Start the air conditioning, due to the low temperature of the engine circulating water, blowing the wind is not hot, the machine needs to work for a period of time to blow out the hot air.

Machine Operations and Controls

Before Starting Engine

Walk-around checks

Before starting the engine, look around the machine and under the machine to check for loose nuts or bolts, or leakage of oil, fuel, or coolant, and check the condition of the work equipment and hydraulic system.

Check also for loose wiring, play, and accumulation of dust at places, which reach high temperatures.

WARNING

- Before inspection and maintenance, the rear engine cover, side door and right front cover must be opened and fixed.
- Clean the flammable materials around the battery, engine muffler or other high-temperature engine parts. Fuel or oil leakage can cause the machine to catch fire. Check carefully and repair any abnormalities or contact the dealer.

During the inspection, if the machine is tilted, make it level before proceeding with the inspection. Before starting the engine every day, check the following items in this section.

1. Check whether the working device, cylinder, connecting rod, hose is damaged, worn or have gaps
Check the working device, cylinder, connecting rod or hose for cracks, excessive wear or gaps. If any problem is found, repair it.
2. Remove dirt and debris from around the engine, battery, and radiator.
Check for dirt accumulated around the engine and radiator. Also check for flammable material (dry leaves, twigs, etc.) around the battery, engine muffler, turbocharger, or other high temperature engine parts. If any dirt or flammable materials are found, remove them.
3. Check for coolant and oil leakage around the engine.
Check for oil leakage from the engine and coolant leaks from the cooling system. If any problem is found, repair it.
4. Check for oil leakage from hydraulic equipment, hydraulic tank, hoses, and joints
Check for oil leakage.
If any problem is found, repair the area where oil is leaking.
5. Check whether the grease pipeline leaks grease.
If any problem is found, repair it.
6. Check whether the monitor is damaged and whether the bolts are loose.

The monitor should be undamaged. If an abnormality is found, replace the parts. Remove foreign objects on the surface.

7. Seat belt and mounting clamps
Check for damage or wear to the seat belt and mounting clamps. If there is any damage, replace with new parts.
8. Check bucket with hook (if equipped) for damage.
Check for damage to the hook, guide, and hook mount. If any problem is found, contact your CFG distributor for repairs.

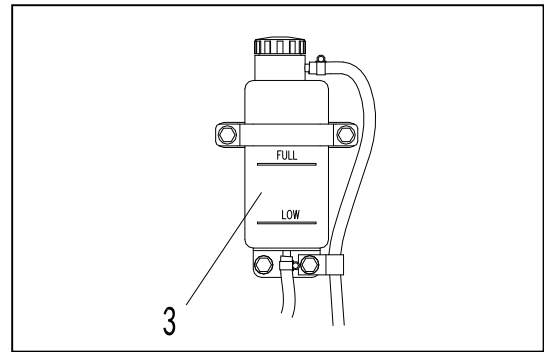

Checks before Starting

Always check the items in this section before starting the engine each day.

Coolant Level: Check or Add

WARNING

- Do not open the radiator cap unless necessary. Wait for the engine to cool down before checking the coolant in the sub-tank.
- Immediately after the engine is stopped, the coolant is at a high temperature and the radiator is under high internal pressure.
If the cap is removed to check the coolant level in this condition, there is a hazard of burns. Wait for the temperature to go down, then turn the cap slowly to release the pressure before removing it.

Check and add the machine at the level of the place.
Check the coolant level before starting every day.

1. Open the rear hood (1), and ensure that the support rod (2) falls into the slot to lock, so as to avoid the side door collision.
2. Check the coolant level of sub-tank (3).
 - If the coolant level is between the FULL and LOW marks means normal.
 - If the coolant level is low, add coolant to the FULL level through the filler port of sub-tank (3).
 - If the sub-tank (3) is empty, there is probably leakage of coolant. After inspecting, repair any problem immediately.
3. At the same time of press the radiator cap (4), unscrew the cove until it comes into contact with the brake and remove the cover. Check the coolant level of the radiator, if lacking of coolant, then add coolant and check whether there is any leakage on line.
4. Check the rubber hoses and pipe clamps for damage, cracks and looseness, and tighten them immediately if they are loose. If damaged, the hose or pipe clamp must be replaced immediately, otherwise the engine is not allowed to start.
Pipe clamp tightening torque of $5.9 \pm 0.49 \text{ N} \cdot \text{m}$ ($60 \pm 5 \text{ kg} \cdot \text{cm}$)

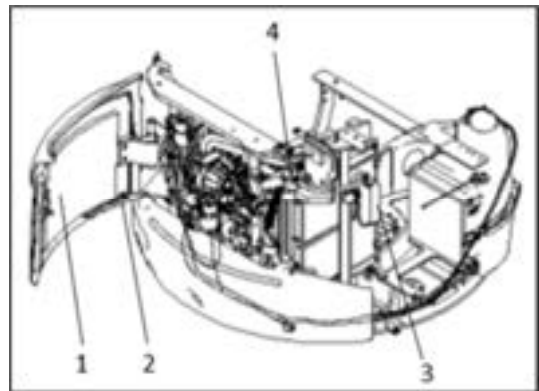

Oil Level in Engine: Check or Add

WARNING

Parts and oil are at high temperature immediately after the engine is stopped and may cause serious burns. Wait for the oil temperature to go down before performing this operation.

NOTICE

When performing inspection and maintenance inside the hood, the hood must be fully opened and locked with struts.

1. Open the hood and lock it with a strut.
2. Remove dipstick (3), and wipe the oil off with a clean cloth.
3. Fully insert dipstick (3) into filler pipe, then remove it.

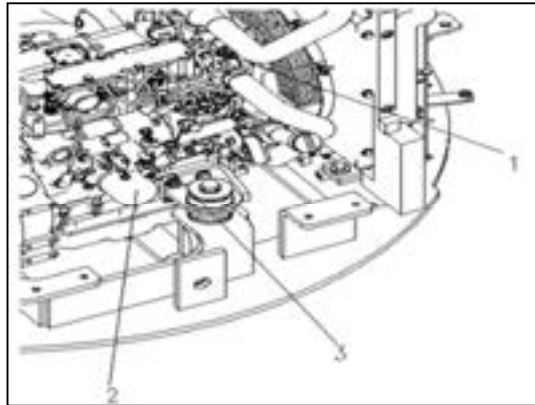

4. The oil level should be between the H and L marks on dipstick (3). If the oil level is below the L mark, add engine oil through oil filler (1).

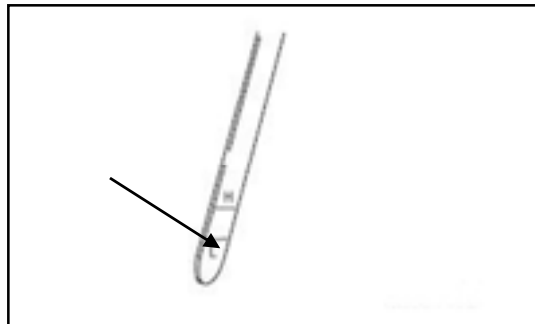

5. If the oil is above the H line, open drain valve (P) at the bottom of the engine oil pan, drain the excess engine oil, then check the oil level again.
6. If oil level is correct, securely tighten the oil filler cap and close the engine hood.

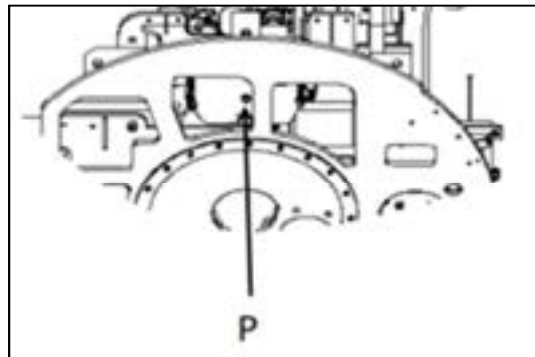

NOTICE

- When checking the oil level after the engine has been operated, wait for at least 15 minutes after stopping the engine before checking.
- If the machine is Inclined, make it to a horizontal position before checking.

Fuel Level: Check or Add

WARNING

When adding fuel, never let the fuel overflow. This may cause a fire. If any fuel is spilled, wipe it up completely. Never bring flames near fuel because it is highly flammable and dangerous.

1. According to the fuel oil level on the monitor to check the amount of oil in tank.
2. If the fuel level is within the red scale of the oil level, add fuel through the injection port (F).
Fuel tank capacity: 19 liters
3. Tighten the cover and locked after refueling.

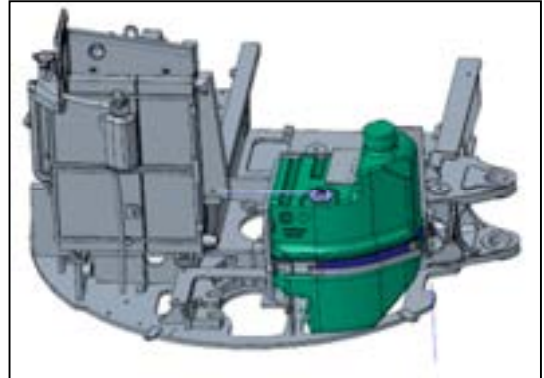

REMARK

- The fuel tank cover is composed of two layers, one of which is connected with a vent. If the vent is blocked or debris enters between the inner and outer layers, the pressure in the fuel tank will drop, the fuel will not flow, and there is a risk of suffocating the fuel tank.
- Clean the hole from time to time.

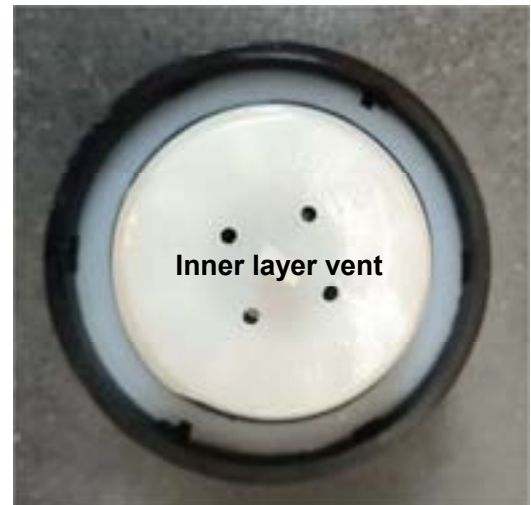

Oil Level of Hydraulic: Check or Add

WARNING

After stopping the engine, the parts and hydraulic oil are still at high temperature, which may cause burns. Therefore, wait until the temperature drops before starting work.

1. If the working device is not in the state shown in the figure on the right, start the engine and run the engine at a low idle speed. Fully retract the arm and bucket cylinder rod, then lower the boom, adjust the bucket teeth to the ground contact position, and turn off the engine.

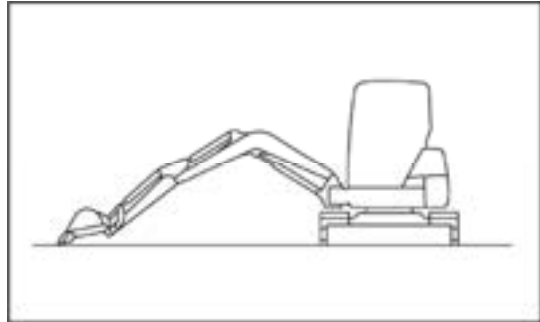

2. Within 15 seconds after turning off the engine, turn the safety lock switch to the ON position, and operate the joystick (working device, walking) in each direction to release the internal pressure.

3. Check the level gauge on the hydraulic oil tank. The oil level must be between the marks on the level gauge, otherwise hydraulic oil needs to be filled.

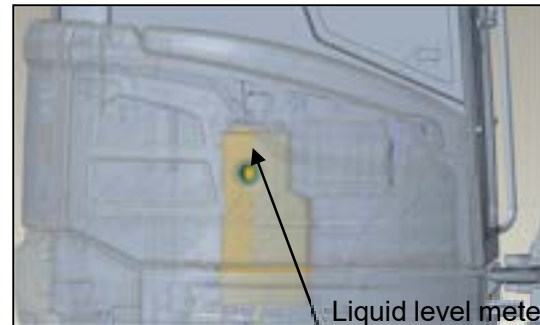

The refueling steps are as follows:

1. Use the key to open the fuel cap lock;
2. Unscrew the fuel filler bolt;
3. Add hydraulic oil and check the level gauge again;
4. Tighten the fuel filler bolt and lock the fuel filler lock.

Air Cleaner Dust Indicator (optional): Check

IMPORTANCE

- Only when the pressure difference indicator (1) pops out and the red mark is visible. The air filter needs to be cleaned, otherwise there is no need to clean the air filter element.
- If the air filter element is cleaned frequently before the pressure difference indicator has not warned, the performance of the air filter will not be fully exerted, and its filtering effect will be deteriorated.
- In addition, the dirt attached to the filter element during cleaning will frequently fall to the inner filter element side and be sucked into the engine, causing engine wear.

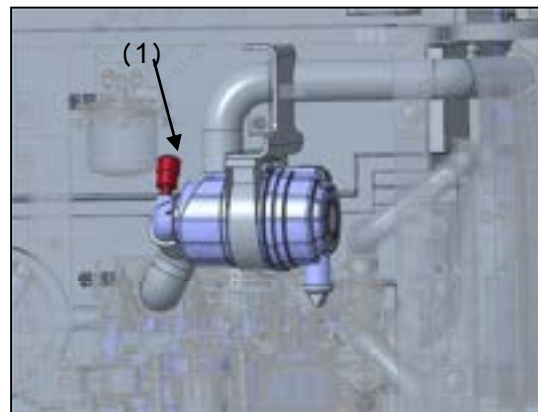

When the pressure difference indicator (1) pops up and shows red, clean or replace the filter element immediately.

- For details about cleaning the filter element, see "Air Filter-Inspection/Cleaning/Replacement" in Inspection and Maintenance.

Fuel pre-filter: check or drain or clean

The fuel pre-filter is inspected and drained, and cleaned if necessary:

1. Open the rear hood of the engine and lock it with a strut.
2. Observe the water cup. If there are impurities inside the water cup, close the valve, place a cloth outside the water cup, use the filter element wrench to turn left to remove the water cup, and clean the water cup with clean diesel.
3. After the water cup is cleaned, use the filter element wrench to turn clockwise to install the water cup back.
4. Open the valve, loosen the strut, and close the rear hood of the engine.

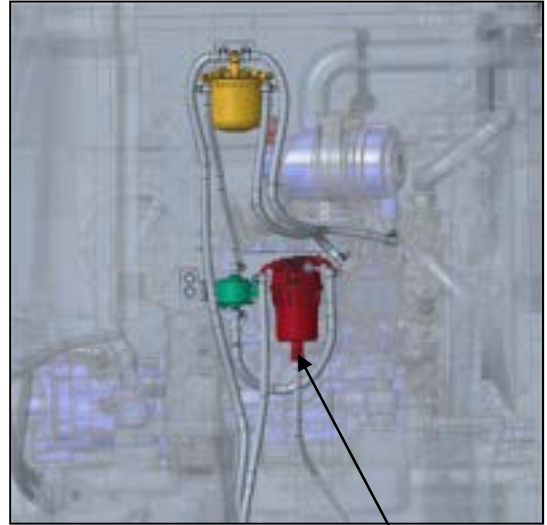

Fuel prefilter vale

IMPORTANT

- The collector cup need to emissions, should not until the pre-filter separator alarm after discharge set the water in the glass, once the fuel oil mixed with water, will cause harm to the engine.

When the water cup has impurities, need to clean the collector cup immediately, or else impurities into the engine block, or engine early wear.

Electric Wiring: Check

WARNING

- If the fuses frequently blow or if there are traces of short circuits in the electrical wiring, locate the cause and immediately perform repairs, or contact your CFG distributor for repairs.
- Be sure to check that there is no inflammable material accumulated around the battery. If present, remove it as soon as possible.
- Keep the top surface of the battery clean and check the breather hole in the battery cap. If it is clogged with dirt or dust, wash the battery cap to clean the breather hole.

Check whether the fuse is damaged and the capacity of the fuse used is appropriate. Check the circuit for signs of open circuit or short circuit, and check whether the terminals are loose. Tighten the loose terminal.

Pay particular attention to the electric wiring when checking the battery, engine starting motor and alternator.

Also check that there is no inflammable material accumulated around the engine. If present, remove it as soon as possible.

For inquiries about the causes and corrective suggestions, please contact your CFG distributors.

Adjustment

! WARNING

- Adjust the operator's seat, control box and rear view mirror before starting each operation or when the operators change shift.
- Adjust the operator's seat so control levers and switches can be operated freely and easily with the operator's back against the backrest.

Seat Adjustment

IMPORTANCE

In order to obtain the best possible comfort, it is important to adjust the seat in the correct way. Statement: Assemble different types of seats and seat adjustment methods are different, please operate according to the actual situation.

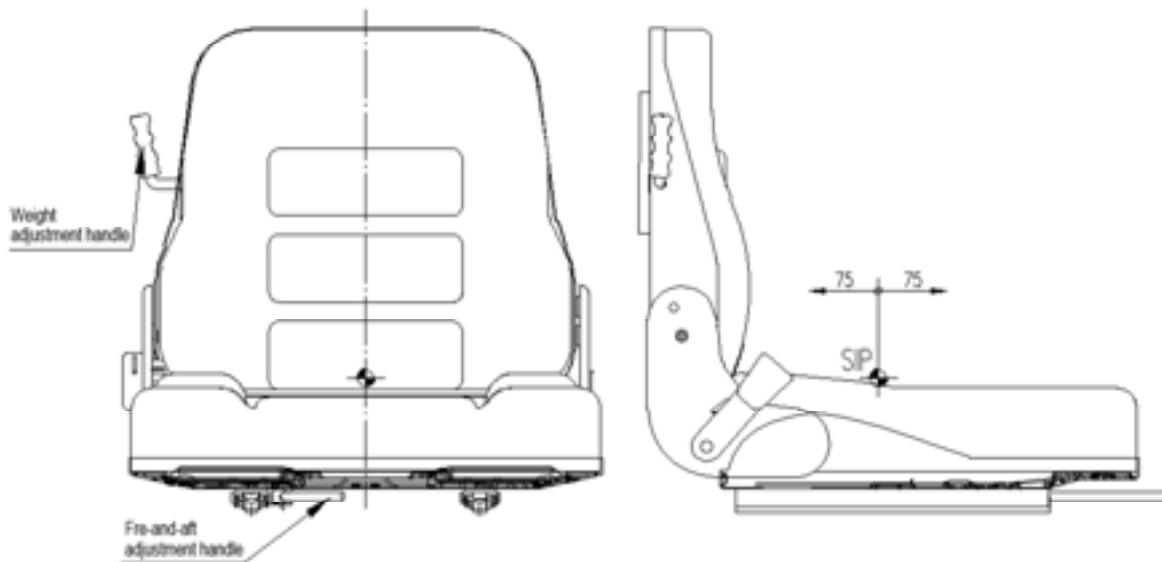

(1) Weight adjustment

According to the operator's own weight, rotate the weight adjustment handle, adjust to the appropriate position. There are three levels of adjustment gears.

(2) Fore-and-aft adjustment

Lift up the seat lever to adjust the entire seat forward or backward. The maximum seat adjustment is 75mm. (This adjustment is the adjustment of the seat rod itself, does not include the adjustment of the slide plate)

(3) Backrest angle adjustment

The seat back can be adjusted forward or backward by a total of 15°.

(4) Seat belt

! WARNING

- Before fitting the seat belt, check that there is no problem in the belt mount bracket or mounting belt. If it is worn or damaged, replace the seat belt.
- Even if no problem can be seen in the belt, replace the seat belt every 2 years.
- To adjust seat before operation.
- Always wear the seat belt during operations.
- Fit the seat belt so that it is not twisted.

If the seat belt is worn or damaged or accidentally deformed, replace the seat belt.

If the seat belt needs cleaning, it must be:

- Use neutral soap liquid.
- Before the belt is rolled up, allow it to dry in the sufficiently stretched condition.

Fasten and unfasten the seat belt

1. Sitting in a seat on the seat, allow the operator back against the seat back of a chair, in order to work.
2. Hold grip and pull the belt out from wind-in device (1), check that the belt is not twisted, then insert tongue (1) into buckle (2) securely.
3. Remove the seat belt, should carry handle with front end, to remove your seat belt.

REMARK

Adjust the fixed card buckle the length of the side, make against the body and avoid kink belt.

Operations before Starting Engine

WARNING

- When starting the engine, check that the lock lever is securely at the LOCK position. If the lock lever is not locked securely and the control levers or control pedal are touched when the engine is started, the machine may move unexpectedly, and this may lead to serious personal injury.
- When standing up from the seat, be sure to set the lock lever at the LOCK position, regardless of whether the engine is running.

1. Confirm the battery cut-off switch in position I (electrify).

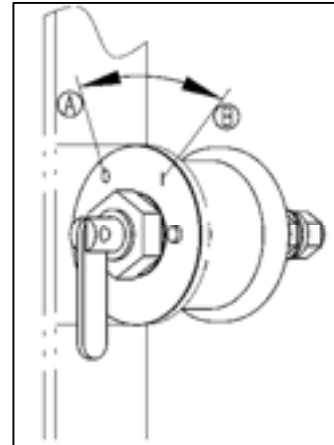

2. Check if the lock lever is at the LOCK position.



NOTE

If lock lever is not at the LOCK position, do not starting engine.

3. Check the position of each lever.

Starting Engine

Normal Starting

WARNING

- Start the engine only after sitting down in the operator's seat.
- Do not attempt to start the engine by short-circuiting the engine starting circuit. Such an act may cause a serious bodily injury or fire.
- Check that there are no persons or obstacles in the surrounding area, then sound the speaker and start the engine.
- Exhaust gas is toxic. When starting the engine in confined spaces, be particularly careful to ensure good ventilation.

IMPORTANCE

Do not crank the starting motor continuously for more than 20 seconds. If the engine does not start, wait for at least 2 minutes before trying again.

1. To ensure the safety lock handle in the locked position, if the safety lock lever is not in the locked position, don't start the engine.

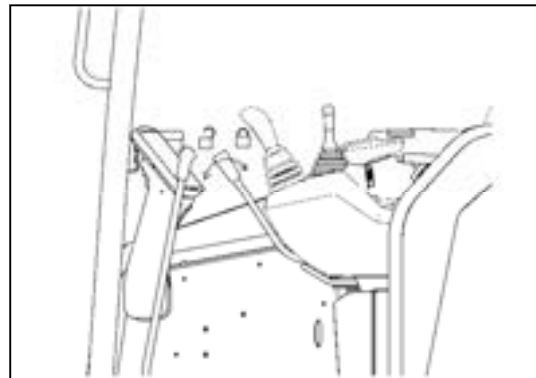

2. Turn the key in starting switch (C) to the START position. The engine will start.

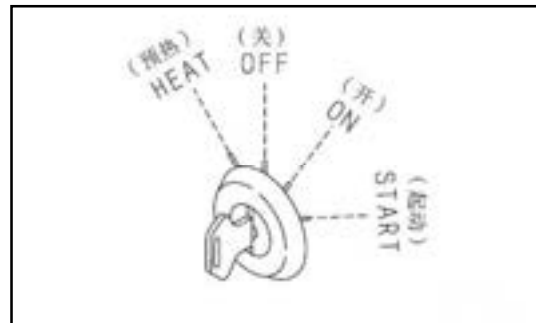

3. After the engine starts, release the key in starting switch. The key will automatically return to the ON position.

Starting Engine in Cold Weather

WARNING

- Start the engine only after sitting down in the operator's seat.
- Do not attempt to start the engine by short-circuiting the engine starting circuit. Such an act may cause a serious bodily injury or fire.
- Check that there are no persons or obstacles in the surrounding area, then sound the horn and start the engine.
- Never use starter aids to start the engine, as they can cause an explosion.
- Exhaust gas is toxic. When starting the engine in confined spaces, be particularly careful to ensure good ventilation.

IMPORTANCE

Do not crank the starting motor continuously for more than 20 seconds. If the engine does not start, wait for at least 2 minutes before trying again.

When starting in low temperatures, do as follows (Machine with warm-up function performs this operation).

1. To ensure the safety lock handle in the locked position if the safety lock lever is not in the locked position, don't start the engine.

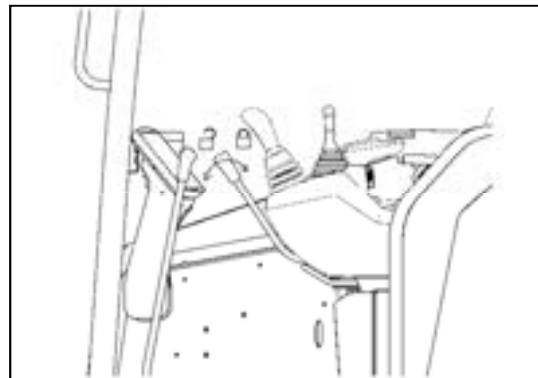

2. Keep the start switch key at the HEAT (preheat) position, the preheating time does not exceed 15s, and it will automatically cut off preheating if it exceeds 15s. After preheating, release the key immediately and it will automatically return to the OFF position.

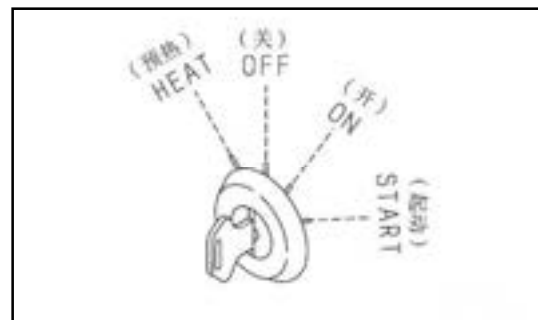

3. Turn the key in starting switch to the START position to start the engine.

4. After the engine starts, release the key in starting switch. The key will automatically return to the ON position.

After Starting Engine

WARNING

- Emergency stop
If any trouble occurs, turn the starting switch to the OFF position.
- If the work equipment is operated without carrying out the warming-up operation properly, the reaction of the work equipment to the operation of the control lever will be slow and the work equipment may not move as the operator intends. To prevent such problems, always be sure to carry out the warming-up operation fully. In cold weather particularly, be extremely careful to carry out the warming-up operation fully.

Breaking in the New Machine

WARNING

The machine has been thoroughly adjusted and tested before shipment from the factory. However, operating the machine under full load before breaking the machine in can adversely affect the performance and shorten the machine life.

Be sure to break in the machine for the initial 100 hours (as indicated on the service meter).

During the running-in operation, observe the precautions required in this manual.

- Run the engine at idle for 5 minutes after starting it.
 - Avoid operation with heavy loads or at high speeds.
- Avoid sudden starts, sudden acceleration, unnecessary sudden stops, and sudden changes in direction.

Warming up operation

IMPORTANCE

- No operation or sudden operation of the joystick is allowed under the condition of low temperature of hydraulic oil. Warm-up operation must be carried out first to prolong the service life of the machine.
- After starting the engine, don't make the engine accelerate suddenly until the warm-up operation is completed. Especially in cold weather, if the engine accelerates suddenly, it will emit white smoke, but this does not mean abnormal.
- Do not run the engine continuously at low or high idle speeds for more than 20 minutes.

If it is necessary to run the engine continuously at idle speed, the engine should be loaded from time to time or run at medium speed.

Do not start operation immediately after starting the engine. First, perform the following operations and checks.

1. Turn fuel control dial to center position between the low idle and high idle positions and run the engine at a mid-range speed about 5 minutes.

REMARK

When the temperature is lower than 0°C, turn the throttle knob to the middle and low speed position for warm-up operation.

Set lock lever slowly and securely to FREE position (F), then raise the bucket from the ground.

2. Place the safety lock lever in the unlock position and raise the bucket from the ground.
3. Slowly operate the left and right joysticks to move the bucket cylinder and stick cylinder to the end of the stroke

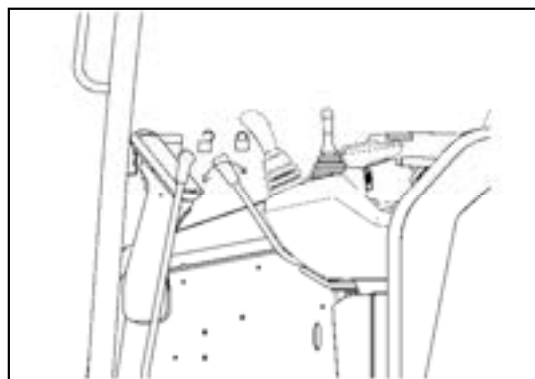

IMPORTANCE

When the work equipment is retracted, take care that it does not interfere with the machine body or ground.

4. Operate the bucket and the arm in turn fully for 5 minutes. (Left handle 1,2 and right handle3,4).
5. After performing the warming-up operation, check and be sure all the gauges on machine monitor and the caution lamps are in the following conditions:
 - Fuel level monitor in the green range;
 - Coolant temperature monitor in the green range;
 - No alarm icon is displayed in the central area of the interface.
6. Check for abnormal exhaust gas color, noise, or vibration. If any problem is found, contact your CFG distributor.
7. Set lock lever slowly and securely to LOCK position, and make sure that the left and right control levers are not operated for turning and operating devices.

Stopping the Engine**IMPORTANCE**

If the engine is stopped abruptly, service life of component parts of the engine may be considerably reduced. Do not stop the engine abruptly except in an emergency.

If the engine has overheated, do not try to stop it abruptly but run it at medium speed to allow it to cool down gradually, and then stop it.

1. Run the engine at low idle speed for about 5 minutes to cool down gradually.
2. Turn the key in starting switch to the OFF position and stop the engine.
3. Remove the key from starting switch.

Check after Shut off Engine

1. Walk around the machine and check the work equipment, machine exterior, and undercarriage, also check for any leakage of oil or coolant. If any problems are found, repair them.
2. Fill the fuel tank.
3. Check the engine compartment for paper and debris. Clean out any paper and debris to avoid a fire hazard.
4. Remove any mud affixed to the undercarriage.

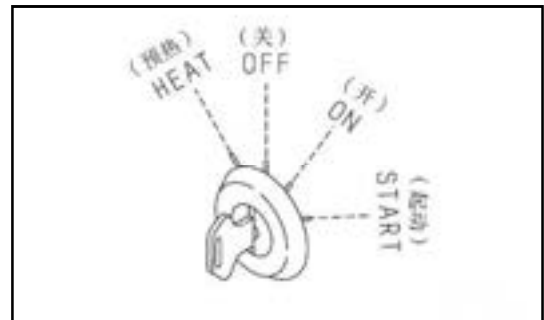

Machine Operation: Move and Stop

Matters Need Attention of Moving the Machine

WARNING

- Before operating the control lever, check the direction of the track frame. If the sprocket is at the front, the machine moves in the opposite direction from the operation of the travel lever.
- Before starting the machine, check that the area around the machine is safe and sound the speaker.
- Do not allow anyone to enter the area around the machine.
- Clear any obstacles from the travel path.
- Here is a blind spot at the rear of the machine, so be particularly careful when traveling in reverse.

Preparation before the machine moves
Pull the throttle lever back to increase the engine speed.



Moving Forward

1. Open the safety lock lever, put away the working device and lift it 40-50cm from the ground.
2. Pull the blade control lever backward to raise the blade.

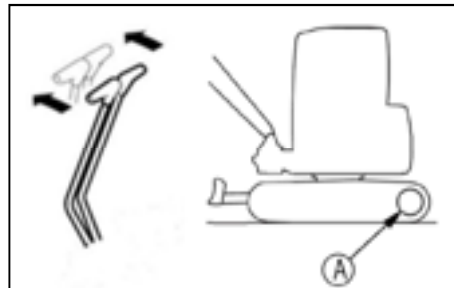

3. Operate the walking joystick according to the following steps.

- When the driving wheel ① is at the back of the machine, slowly push the left and right walking joysticks forward to move the machine.
- When the driving wheel ① is at the front of the machine, slowly pull the left and right walking joysticks back to move the machine.

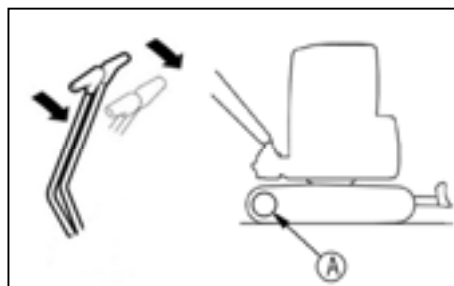

4. Follow the steps below to switch the walking speed.
Press the walking speed switch to the high-end "rabbit gear" to switch from low-speed walking to high-speed walking.
Press the walking speed switch to low gear to switch from high speed to low speed.

Moving Machine Backward

1. Raise the safety lock lever, put away the working device and lift it 40-50cm from the ground.
2. Pull the dozer lever backward to raise the dozer.

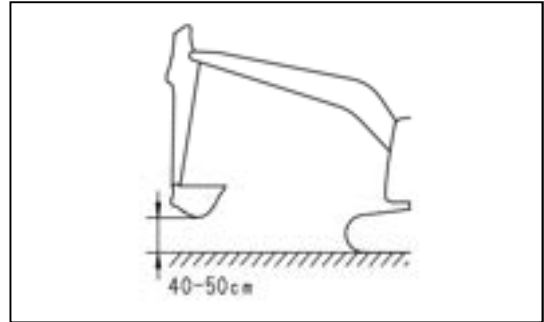

3. Operate the travel levers as follows:
 - When sprocket (A) is at the rear of the machine:
Slowly pull the joystick back to move the machine.

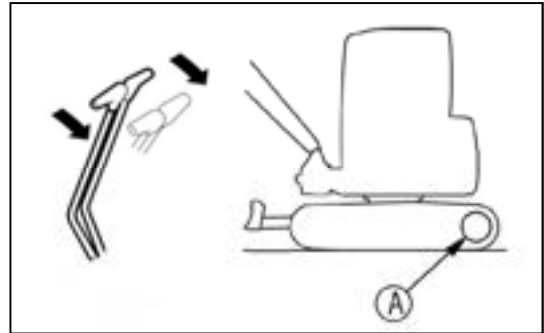

- When sprocket (A) is at the front of the machine:
Slowly push the joystick forward to move the machine.

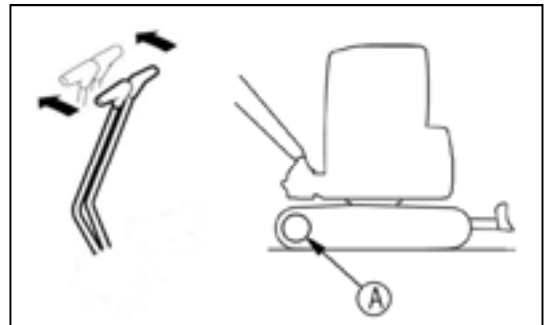

4. The walking speed switching mode is consistent with the "speed forward" method.

Stopping Machine

Avoid stopping suddenly. Give yourself ample room when stopping.

1. Put the left and right travel levers in the neutral position, then stop the machine.

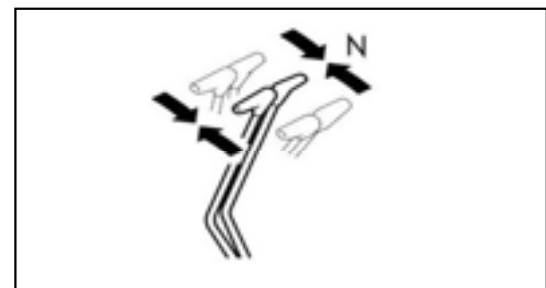

Steering the Machine

Steering

WARNING

Before operating the travel levers, check the direction of the track frame. If the sprocket is at the rear, the machine moves in the reverse direction to the operation of the travel levers.

Use the travel levers to change direction. Avoid sudden changes of direction as much as possible. Especially when performing counter-rotation (spin turn), stop the machine before turning. Operate two travel levers as follows.

Steering the machine when stopped

When turning to the left, Push the right travel lever forward to turn to the left when traveling forward; and pull it back to turn left when traveling in reverse.

(A): Forward left turn

(B): Reverse left turn

REMARK

When turning to the right, operate the left travel lever in the same way.

Changing direction of the machine when moving straight

When turning to the left:

If the left travel lever is returned to the neutral position, the machine will turn to the left.

(A): Forward left turn

(B): Reverse left turn

REMARK

When turning to the right, operate the right travel lever in the same way.

Counter-rotation turn (spin turn)

When rotating to the left, pull the left walking joystick back and push the right walking joystick forward.

REMARK

When using counter-rotation to turn right, pull the right travel lever back and push the left travel lever forward.

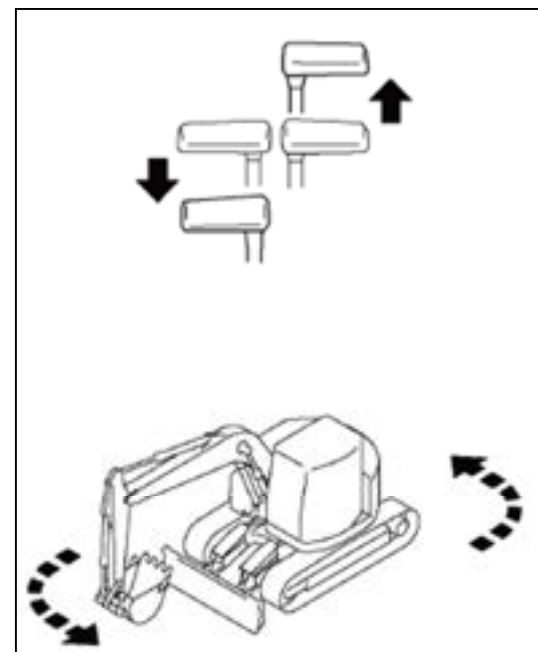
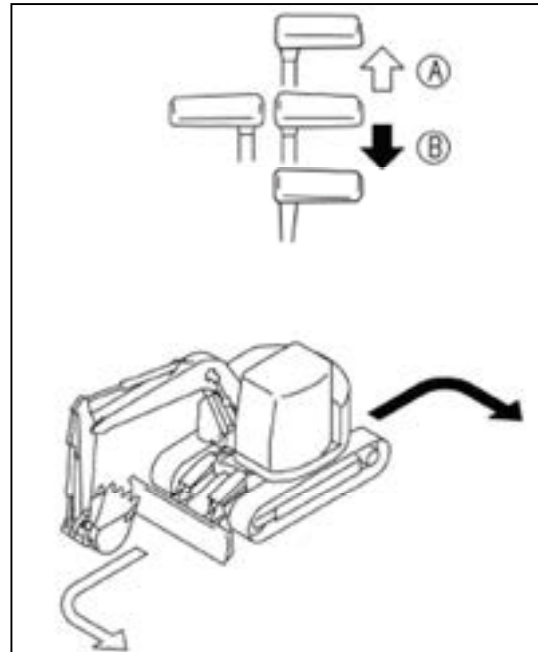

Swinging



WARNING

Before operating the swing, check that the area around the machine is safe.

REMARK

- When swinging on the ramp, you should operate the engine at a low speed and operate the swing control lever at a micro operation
- Especially in the bucket load state, should avoid sudden operation.
- When the bucket is on load, the brake of the parking brake can be released by operating the left work equipment control lever. There will be an instant return, but this is not unusual.

Work Equipment Controls and Operations



WARNING

This operation is only for the standard operation mode (ISO mode). For other operation modes, please contact your dealer.

Use the control levers to operate the work equipment

When the levers are released, they return to the middle position and the work equipment is held in that position.

□ Arm operation

Operate the left control lever forward (1) or backward (2) to control the arm.

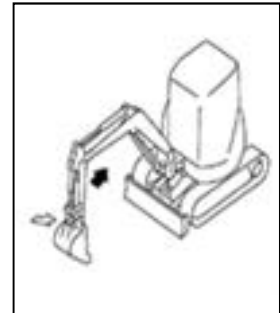
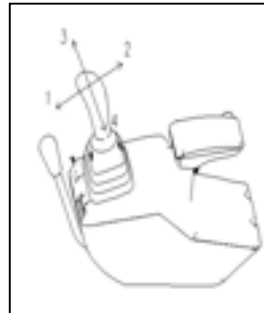

□ Swing operation

Operate the left control lever to the left (3) or right (4) to swing the upper structure.

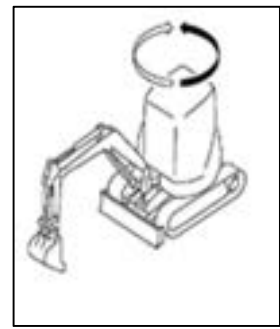
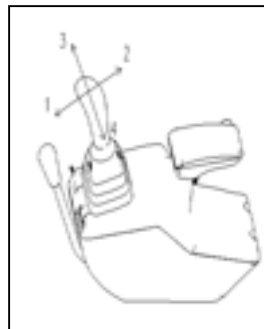

□ Boom operation

Operate the right control lever forward (1) or backward (2) to operate the boom.

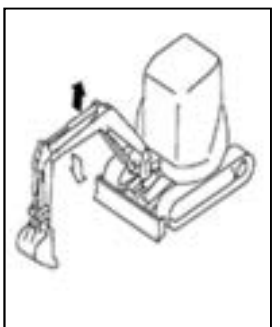
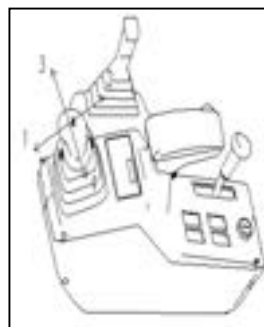

□ Bucket operation

Operate the right control lever to the right (3) or left (4) to operate the bucket.

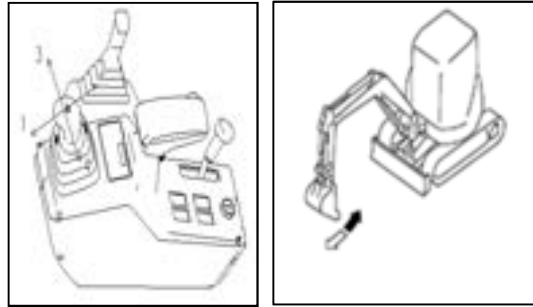

□ Blade operation

Move the blade lever forward or backward to operate the blade.

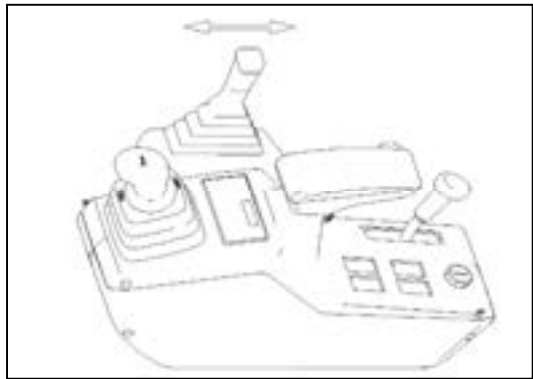

REMARK

When the engine stops, if necessary, lower the working device to the ground or release the residual pressure in the hydraulic circuit and do this as follows.

1. Turn the key to the ON position, lift the safety lock lever to position.
2. Operate the required action, at this time the working device will operate in accordance with the control handle slowly. Move the handle back and forth a few times to release the internal pressure fully.
3. Turn the key to the OFF position, put down the safety lock lever.

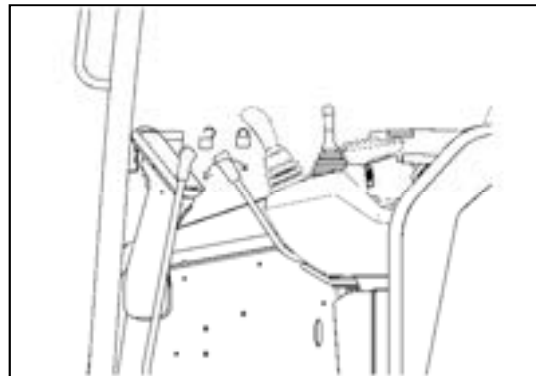

REMARK

- The control action requires the ability to descend under the action of its own gravity.
- Generally, the action can be able to control including a bucket arm eversion, boom down, dozer down.

WARNING

When carrying out hydraulic system maintenance (joint hose disassembly and replacement, etc.) must release pressure, otherwise it will cause serious injury.

Operation with Hook Bucket

Precautions for Lifting

- Do not exceed the specified lifting load.
 - Use wire rope that conforms to the specified standard.
 - Do not carry out lifting work on slopes, soft ground, or other places where the machine is not stable.
 - It is dangerous if the raised load is too heavy and shakes. Slow down the engine speed and operate the operating handle slowly.
 - Do not start, swing, or stop the machine suddenly. There is a hazard that the lifted load will swing.
 - Do not use the work equipment or swing to pull the load in any direction. There is danger that the hook may break and the load come off, causing the work equipment to move suddenly and cause personal injury.
 - Do not use two machines together to enhance operations, it is very dangerous.
 - Do not leave the operator's seat when there is a raised load.
 - Prohibited for pulling pile operation.
 - It is dangerous if the raised load hits any person or structure. When swinging or operating the work equipment, check carefully that the surrounding area is safe.
 - Do not run the machine while lifting
-
- Depending on the work posture, the wire rope and rings may fall off the hook. In order to prevent this, should pay special attention to the angle of the hook.

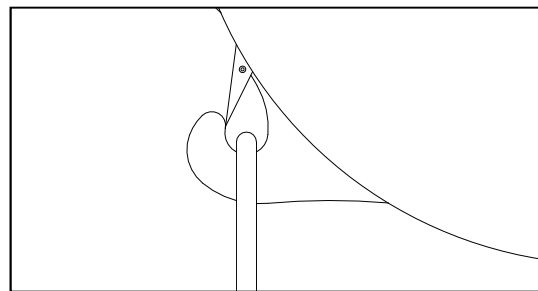
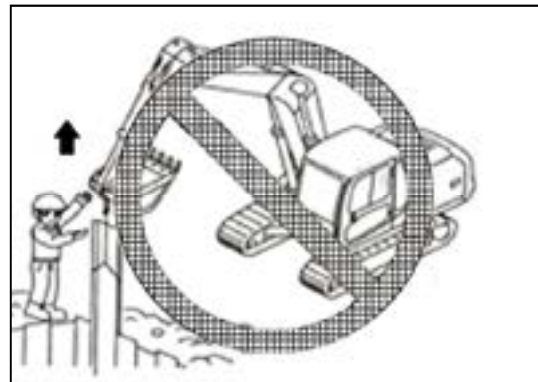
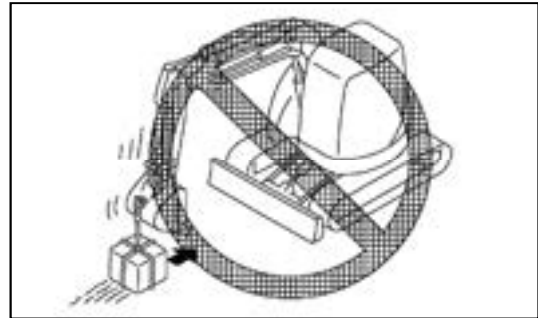
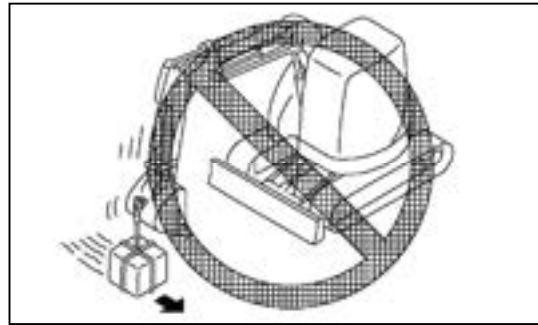

NOTICE

Please do not enter the area under the lifting weight and its surrounding.

- When turning the bucket with a hook, be careful to avoid interference with the boom and the body during bucket unloading.

WARNING

This machine bucket with hooks for auxiliary construction use, non-special lifting hooks, Professional lifting hooks must be equipped with anti-off hooks.

Any problems caused by using the machine with its own non-special hook for lifting operation have nothing to do with our company!

If you need special hoisting hook, please contact CFG Distributor.

Prohibited Operations



WARNING

- If it is necessary to operate the working device while the machine is walking, be especially careful when operating.
- If you operate any joystick when the deceleration is in effect, the engine speed will suddenly increase, so be careful when operating.

Operations Using Swing Force

Do not use rotational force to compact the ground or broken objects. And during the turning process, do not dig the bucket teeth into the ground. Doing so will damage the working device.

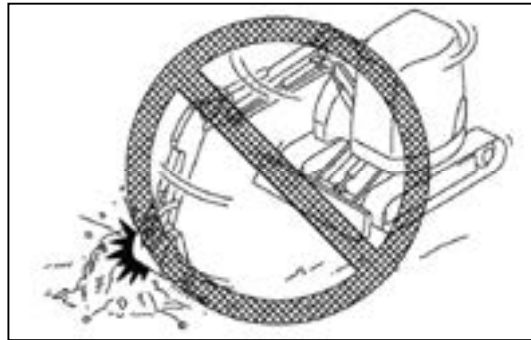

Operations Using Travel Force

Do not dig the bucket into the ground and use the travel force to carry out excavation. This will damage the machine or work equipment.

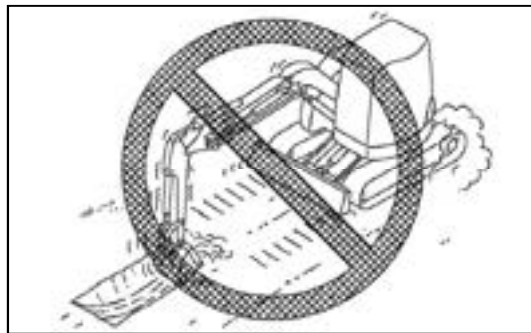

Operations Using Stroke Ends of Hydraulic Cylinders

If the work equipment is used with the cylinder rod operated to its stroke end, and given impact by some external force, the hydraulic cylinders will be damaged, causing personal injury. Avoid operations with the hydraulic cylinder fully retracted or fully extended.

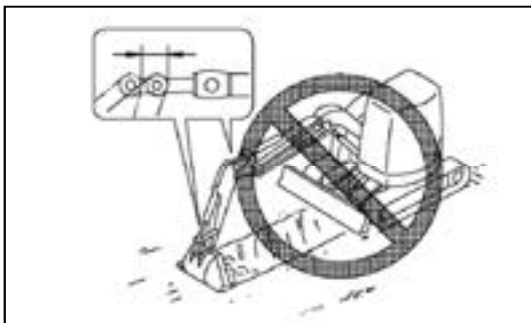

Digging Hard Rocky Ground

It is better to excavate it after breaking up by some other means. This will not only save the machine from damage but will make for better economy.

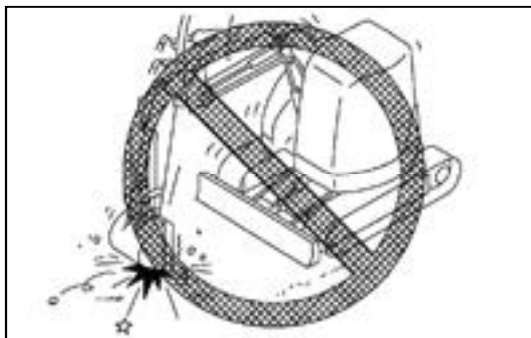

Operations Using Bucket Dropping Force

Use the descending force of the working device to excavate, use the descending force of the bucket as a pick, or use the bucket for impact excavation or pile driving. Doing so will generate excessive force. In addition to causing damage to the machine, it is also very dangerous, so do not Do this.



Operations Using Machine Dropping Force

Do not use the descending force of the machine for digging. The hard rocky ground is best broken by other methods first, and then excavated. This will not cause damage to the machine and is more economical. Do not use the descending force of the machine for digging.

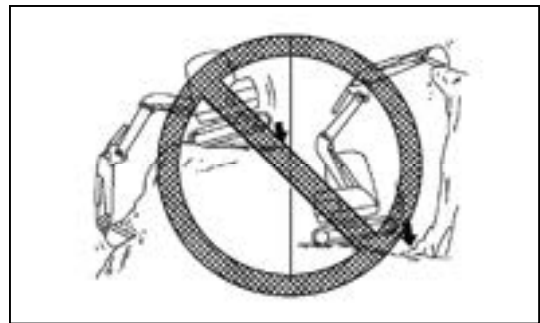

Prohibit Lifting Operations

It is prohibit to use this machine for lifting operations, but it is not restricted when a special lifting hook is installed. Refer to "Operation with Hook Bucket".

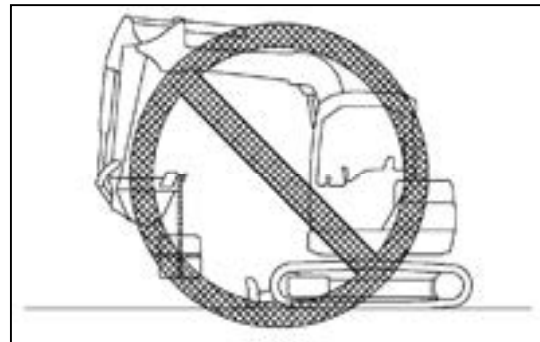

Sustain Blade on Both Sides

Do not sustain the machine with one end of the blade when using blade.

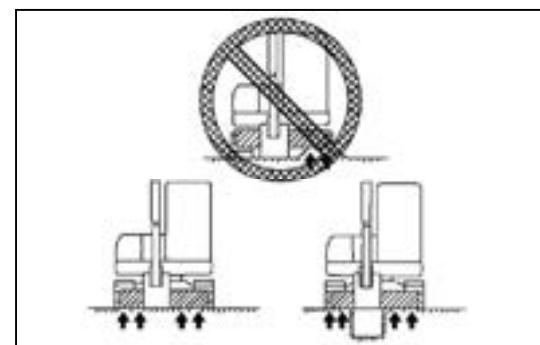

General Operation Information

Traveling

When walking on obstacles (such as gravel, tree stumps), the machine (especially the lower walking device) will withstand a great impact, resulting in damage to the machine. Therefore, such obstacles should be removed as much as possible and avoid walking on obstacles. As a last resort, reduce the walking speed, keep the working device close to the ground, and make the center of the crawler cross over obstacles.

Avoid Blade Impacted

Do not given impact by some stones or road shoulder, this will premature damage the blade or hydraulic cylinders.

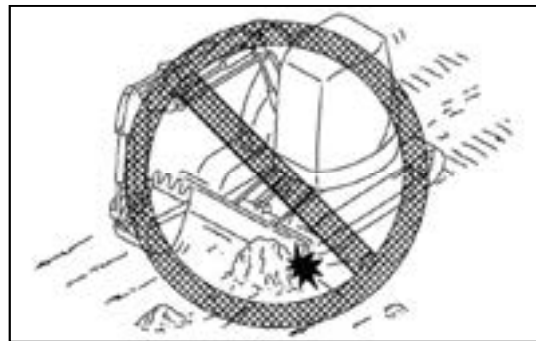

Fold the Work Equipment

Be careful not to allow the bucket to impact the blade when the work equipment is folded in traveling or transport attitude.

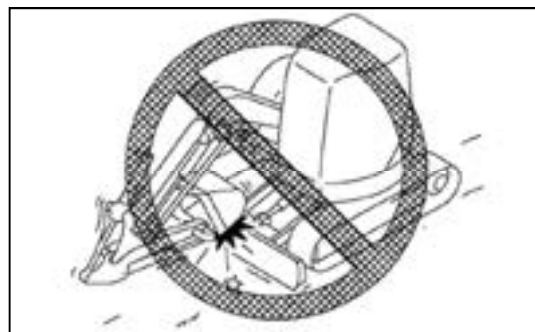

Blade in Backhoe Operation

When the excavator is in deep excavation while the blade is at the front, be careful not to impact the blade with the boom cylinder. In addition to the blade must be in the front, insure put the blade placed in the rear.

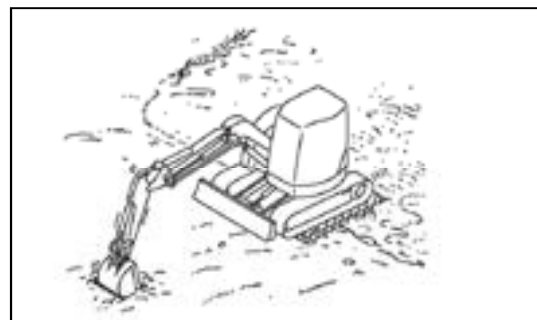
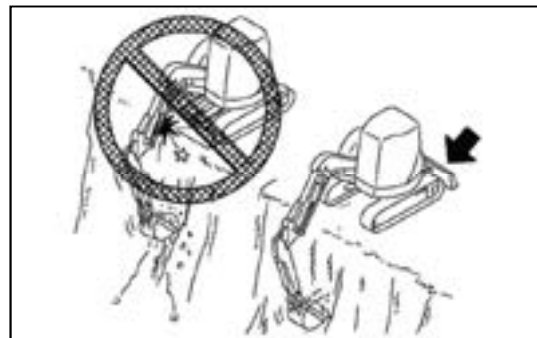

Permissible Depth of Water

WARNING

When driving the machine out of water, if the angle of the machine exceeds 15°, the rear of the upper structure will go under water, and water will be thrown up by the radiator fan. This may cause the fan to break.

Be extremely careful when driving the machine out of water.

Do not drive the machine in water deeper than the center of carrier roller.

Supply grease to the parts which have been under water for a long time until the used grease is projected out of the bearings (around the bucket pin, in particular).

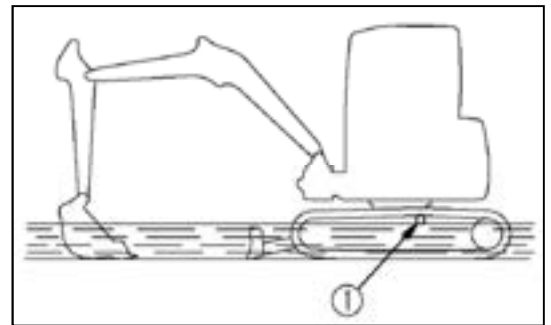
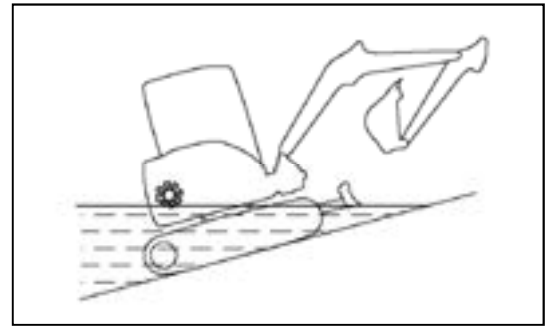

Traveling on Slopes

WARNING

- Turning or operating the work equipment when working on slopes may cause the machine to lose its balance and turn over, so avoid such operations. It is particularly dangerous to swing downhill when the bucket is loaded. If such operations have to be performed, pile soil to make a platform (A) on the slope so the machine is kept horizontal during operation.
- Do not travel up or down steep slopes. There is a danger that the machine may turn over.
- When traveling, raise the bucket approx. 20 to 30 cm from the ground. Do not travel downhill in reverse.
- Never turn on slopes or travel across slopes. Always go down to a flat place to perform these operations. It may have belonged, but it will ensure safety.
- Always operate or travel in such a way that it is possible to stop safely at any time if the machine slips or becomes unstable.
- When traveling uphill, if the shoes slip or it is impossible to travel uphill using only the force of the tracks, do not use the pulling force of the arm to help the machine travel uphill. There is danger that the machine may turn over.

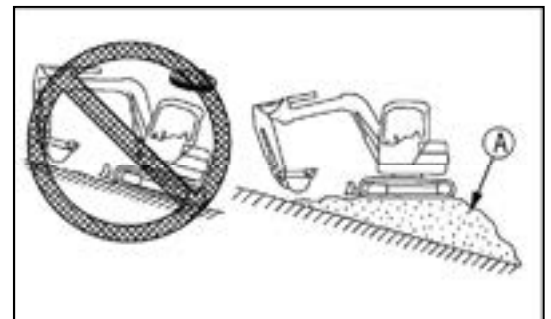
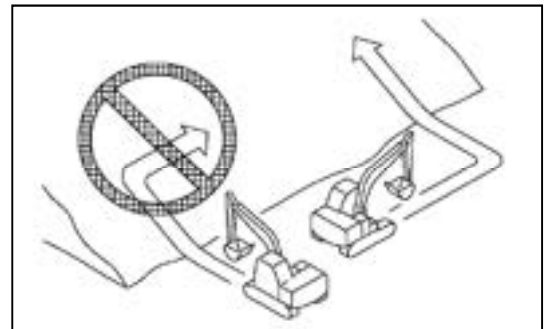

1. When traveling down steep hills, use the travel lever and fuel control dial to keep the travel speed low. When traveling down a steep hill of more than 15° , set the work equipment to the posture shown in the diagram on the right and lower the engine speed.

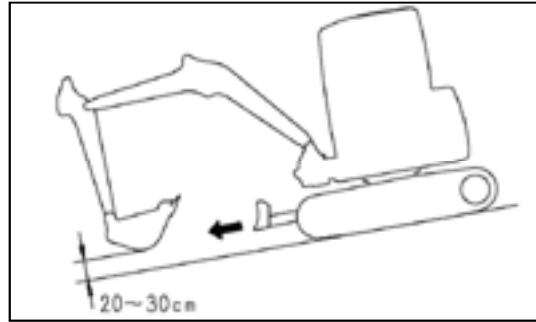

REMARK

When traveling downhill, the sprocket side ① in the downhill side.

If the machine goes downhill, the side of the drive wheel ① is on the uphill side, the crawler tends to
It will relax and cause tooth skipping.

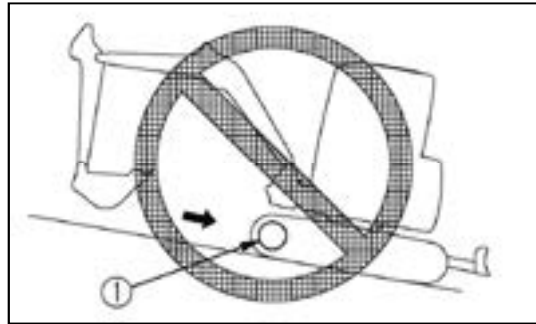

2. When traveling up a steep hill of more than 15° , set the work equipment to the posture shown in the diagram on the right.

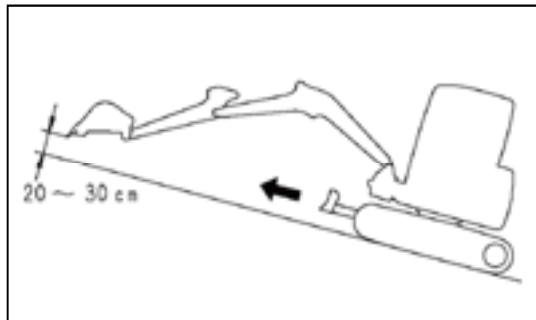

Traveling Downhill

Put the travel lever in the middle position. This will cause the brake to be automatically applied.

□ Engine Stopped on Slope

If the engine stops when traveling uphill, move the travel levers to the middle position, lower the bucket to the ground, stop the machine, then start the engine again.

□ Notes on Slopes

Even if the engine is turned off on a slope, if the left working device joystick is used for turning operations, the upper turning platform will turn due to its own weight. Therefore, turning operations must not be performed.

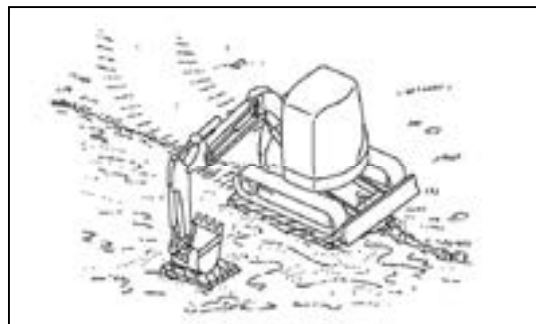

Recommended Applications

In addition to the following, it is possible to further increase the range of applications by using various attachments.

Backhoe Work

A backhoe is suitable for excavating areas that are lower than the machine.

When the condition of the machine is as shown in the diagram on the right (angle between [bucket cylinder and link] and [arm cylinder and arm] is 90°), the maximum excavation force is obtained from the pushing force of each cylinder.

When excavating, use this angle effectively to optimize your working efficiency.

The range for excavating with the arm is from a 45° angle away from the machine to a 30° angle towards the machine.

There may be some differences depending on the excavation depth, but try to stay within the above range rather than operating the cylinder to the end of its stroke.

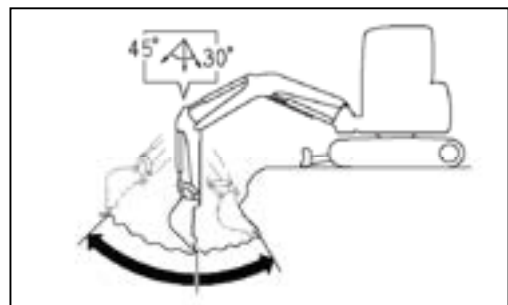
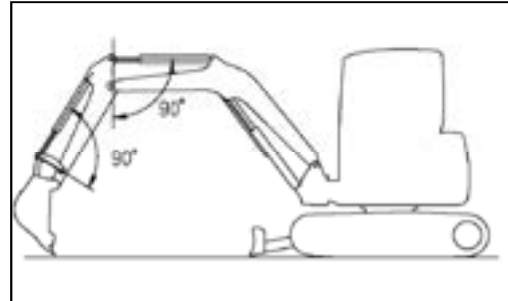

Ditching

Ditching work can be performed efficiently by attaching a bucket which matches the digging operation and then setting the tracks parallel to the line of the ditch to be excavated.

To excavate a wide ditch, first dig both sides and then finally remove the center portion.

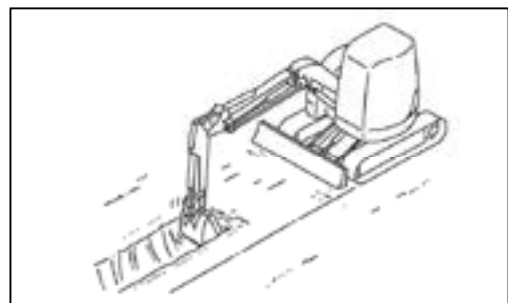

Loading Work

In places where the swing angle is narrow, work efficiency can be enhanced by locating the dump truck in a place easily visible to the operator.

Loading is easier and capacity greater if you begin from the behind of the dump truck body than if loading is done from the side.

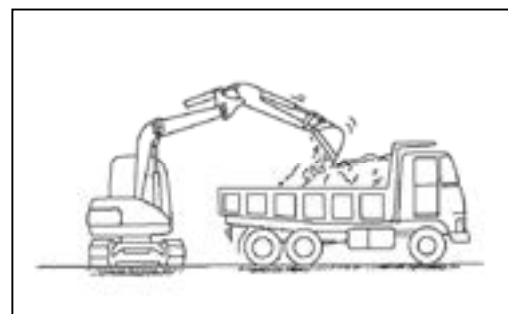

Smoothing Operation

Use the plow to carry out the landfill and smooth operation after excavation.

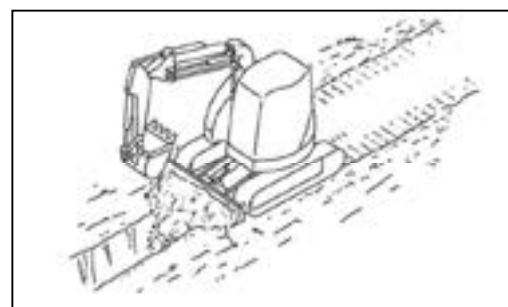

Bucket Replacement and Inversion

WARNING

- When pins are knocked in with a hammer, pieces of metal may fly and cause serious injury. When carrying out this operation, always wear goggles, hard hat, gloves, and other protective equipment.
- When the bucket is removed, place it in a stable condition.
- If pins are hit with a strong force, there is a hazard that the pin may fly out and injure people in the surrounding area. Make sure that there is no one in the surrounding area before starting the operation.
- When removing the pins, do not stand behind the bucket. In addition, be extremely careful not to put your foot under the bucket while standing at the side for the work.
- When removing or inserting pins, be extremely careful not to get your fingers caught.
- Never insert your fingers into the pin holes when aligning the holes.

IMPORTANT

After removing the pins, make sure that mud or sand does not get on them. Dust seals are fitted at both ends of the bushings, be careful not to damage them.

Stop the machine on a firm and flat surface and do the work. When performing joint work, appoint a lead and follow that person's instructions and signals.

1. Place the bucket in contact with a flat surface. Remove the nut and bolt on (A) (B), pull out pin (A) (B).

REMARK

- When removing the pins, place the bucket so that it is in light contact with the ground. If the bucket is lowered strongly to the ground, the resistance will be increased and it will be difficult to remove the pins.
- After removing the pins, make sure that mud or sand does not get on them.

2. Align the arm with holes (1) of the new bucket and the link with holes (2), install washer O-ring then insert rease-coated pins (A) and (B) into hole (1) and hole (2) respectively.

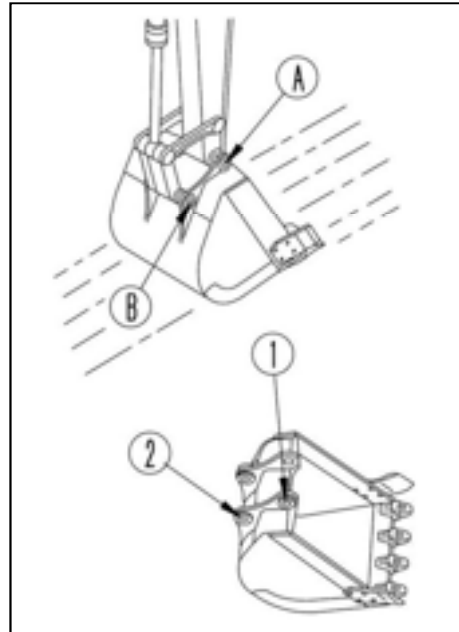

REMARK

- When installing bucket. the O-ring is damaged easily, so installing the O-ring on the bulge tower of the bucket as shown.
- When beating pins, move the O-ring down to the standard groove.

3. Install the bolts and nuts for each pin, then grease the pin (A) (B) through fitting grease.

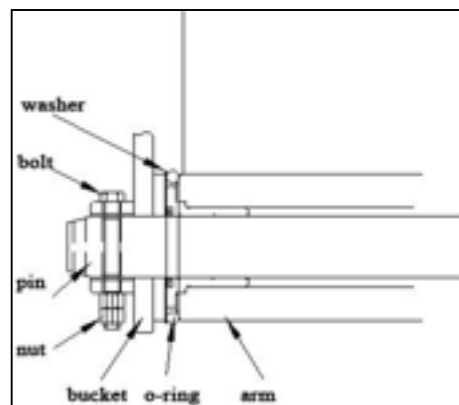

Parking Machine

WARNING

- Avoid stopping suddenly. Give yourself ample room when stopping.
- When stopping the machine, select flat hard ground and avoid dangerous places.
- If it is unavoidably necessary to park the machine on a slope, insert blocks underneath the track shoes. As an additional safety measure, thrust the bucket into the ground.
- If the control lever is touched by accident, the machine may move suddenly, and this may lead to a serious accident. Before leaving the operator's compartment, always set the lock lever securely to LOCK position.
- Set the blade to the downhill position and touch the ground.

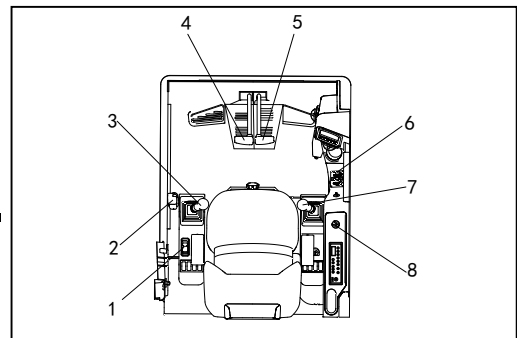
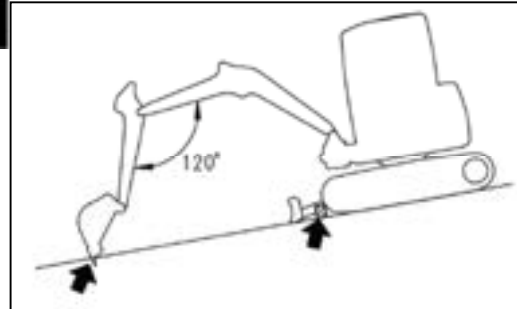

1. Put left and right travel levers (4) (5) in the neutral position, then to stop the machine.
2. Turn fuel control dial to lower the engine speed to low idle.
3. Lower the bucket horizontally until the bottom touches the ground.
4. Lower the blade until the bottom touches the ground.

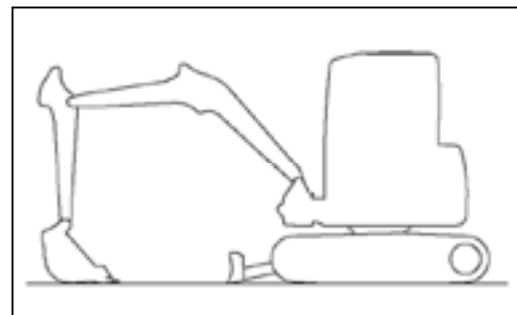
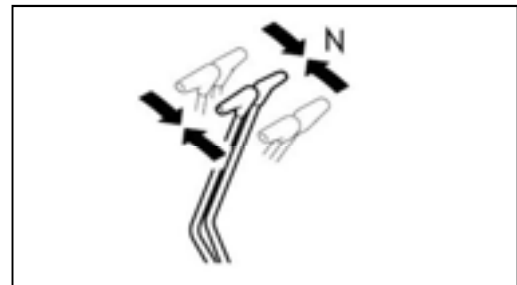

5. Set lock lever in the LOCK position (L).

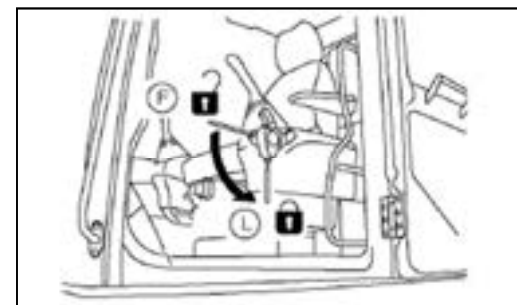

Check After Completion of the Job

Before shutting down the engine

Check the engine cooling water temperature and engine oil pressure with the machine monitor. If the coolant temperature gauge is in the red range, allow it to cool until the indicator enters the green range, then stop the engine. If the engine oil pressure monitor lights up, stop the engine immediately.

Check after Shut off Engine

1. Walk around the machine and check the work equipment, machine exterior, and undercarriage, also check for any leakage of oil or coolant. If any problems are found, repair them.
2. Fill the fuel tank.
3. Check the engine compartment for paper and debris. Clean out any paper and debris to avoid a fire hazard.
4. Remove any mud affixed to the undercarriage.

Locking

Always lock the following places.

- (1) Right cover
- (2) Rear cover

Rubber Pad Shoe and Road Liner

A machine equipped rubber pad shoe or road liner.

Instructions of Rubber Pad Shoe and Road Liner

An excellent performance of a rubber pad shoe and road liner having a metal pad shoe. But if it is the same as the metal pad shoe. The ways in which they are used cannot be fully utilized.

In order to suit the working conditions and the nature of the work, in the case of rubber pad shoe without deformation.

Comparison of pad shoe

	Rubber track shoe	road liner	metal track shoe
Vibration	excellent	excellent	common
Travel smoothly	excellent	well	well
noise	excellent	excellent	common
Don't destroy paver surface	excellent	excellent	common
convenience	excellent	common	common
duration	common	well	excellent
traction force	excellent	excellent	excellent

Taking into account the characteristics of the material, the rubber pad shoe and the road liner have various advantages. Their weakness is not enough strength. So, to understand the advantages of rubber pad shoe and road liner, we must comply with the operation and prohibit operation of the attention is very important. This will prolong the service life and make the machine fully show the advantages of the rubber pad shoe and the road liner. Be sure to observe the following instructions, when using a machine equipped rubber track shoe or road liner.

The Maintenance of Rubber Pad Shoe and Road Liner

Be sure to check and maintain pad shoe, keep it in a proper degree of tightness. Particularly the following jobsites must be avoided. Such as steel side, U-shaped groove, block, gravel, stone, iron stick, iron scurf.

Any damage caused to the user by the use of the machine is not within the scope of the warranty.

Use Rubber Pad Shoe and Road Liner

Forbidden operation

Particularly the following jobsites must be avoided:

- Operating and turning in sharp hard rock gravel, I-beam, iron or steel, it may cause damage to the rubber pad shoe and road liner.
- In places where there are a large number of pebbles, stones can squeeze into and damage the rubber pad shoe and the road liner, or make the crawler board fall off. The service life of the rubber pad shoe and the road liner can be shortened if the track board is carried out when the crawler board is skid.
- Don't let oil, fuel or chemical solvents on rubber pad shoe and road liner. If the material is on the pad shoe, remove it immediately. In addition, don't walk on the oil road.
- When the machine is stored for a long time (three months or longer), should be stored in the machine room, to prevent the sun and rain.
- Do not use the machine in high temperature areas, such as the burning of wood, the hot sun exposure of the steel plate or the place has been paved with asphalt.
- Do not move the machine in the case of one side of the track with the working device, this will damage the rubber pad shoe and make it plate off.
- When the rubber part of the road liner is worn or damaged, or the bolt head is installed, the track plate should replace at once. If the bolt head is broken, it will be difficult to remove.
- When install the road liner must be to all sides of the link. If installed only in part on the chain, its durability will be significantly reduced.

Extend the service life

When working, observe the following points:

- Avoid turning on the concrete pavement.
- Avoid sudden changing in the direction of walking, so that the rubber pad shoe and the road liner is too early wear or damage.
- When crossing a large gap between the place, should avoid steering operation, When crossing the divide large obstacles or place, should make machine go straight across obstacles to prevent crawler plate off.
- If machine has been used when the bucket is lifted, slowly falling.
- To avoid the extrusion of the oil material (beans, grains or oily vegetables) job, or wash machines after using.
- To avoid damaging the steel core adhesion material, such as salt, ammonium sulfate, potassium chloride, potassium sulfate or calcium super phosphate operation, or wash machines after using.
- Salt can destroy the steel core near the attachment, so avoid working in the beach area.
- When the salt, sugar, wheat and beans during the operation, if the rubber pad shoe and road liner have deep scratches, these substances will enter the rubber lines or scratch, to repair the rubber pad before using.
- Don't involve scraping wall or concrete embankment work.
- In the snow or frozen road, rubber pad shoe and road liner is very easy to slip. When walking or working on the ramp, pay attention not to slip.
- When working in a cold area, the characteristics of rubber pad shoe and road liner will change, which will shorten the service life of the rubber pad shoe and road liner.
- Use a machine equipped with rubber pad shoes or road Liner in the ambient temperature range of -25°C to 65°C due to the properties of rubber.
- When the bucket operating, pay attention to the rubber pad shoe and road liner don't be damaged by bucket.
- We must make rubber pad shoe maintain appropriate tension to prevent loss.

If the tension is low, rubber pad shoe will fall off in the following conditions:

1. When skipping over the edge of the road, stones or a larger gap (about more than 20cm (8in)) should not steer. When crossing the obstacles, walk at right angles to the obstacles.

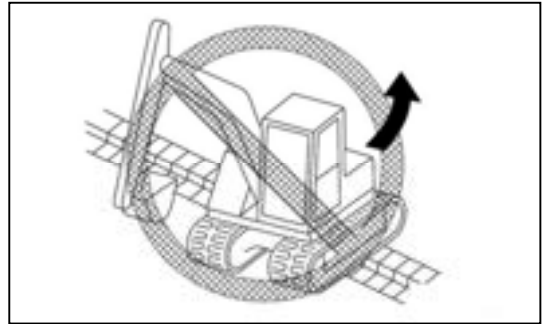

2. When reverse the slope, do not turn in the course of moving from the ground. If you must turn on the slope, be sure to move slowly.

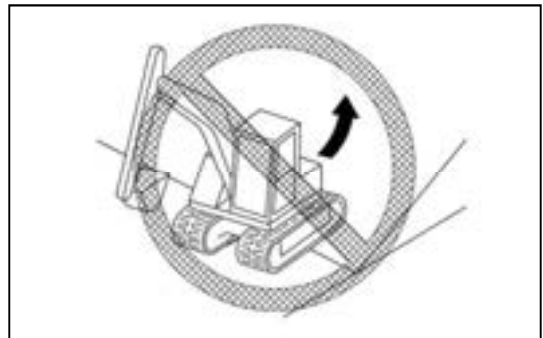

3. To avoid walking along the edge of the slope or on uneven ground, resulting in one side of the track lifted (machine inclination of more than 10 degrees), the other side of the track on the ground. In order to avoid damaging to rubber pad shoe and road liner, walking on both sides of tracks on the ground.

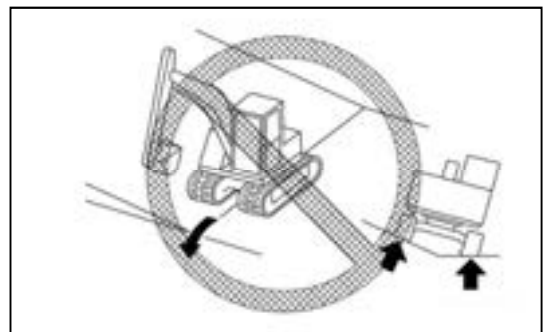

4. If according to the above 1~3 operate the machine, rubber pad shoe will become loose. Don't let the machine turn in the position shown in the picture.

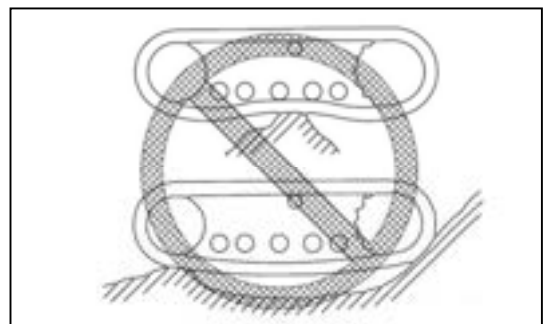

The principle of the rubber pad shoe fall off

1. When walking on the obstacle, a gap is formed between the track supporting wheel and rubber pad shoe. In this case, rubber pad shoe will fall off.

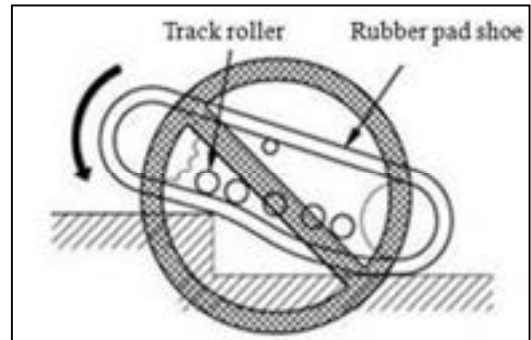

2. In addition, if machine is running backwards, a gap is formed between the track supporting wheel, guide wheel and rubber pad shoe.

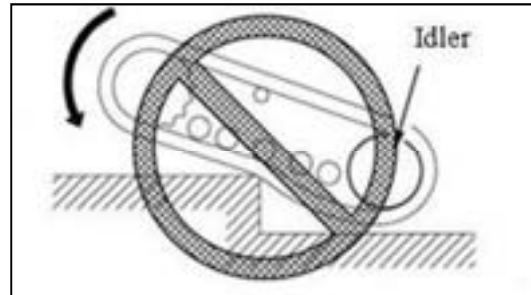

The condition of rubber pad shoe fall off

- When turning over, in the case of the rubber pad shoe can't be moved to the side due to the crossing of an object or a certain other object.
- When rubber pad shoe is not a straight line and guide wheel or supporting wheel not at central.

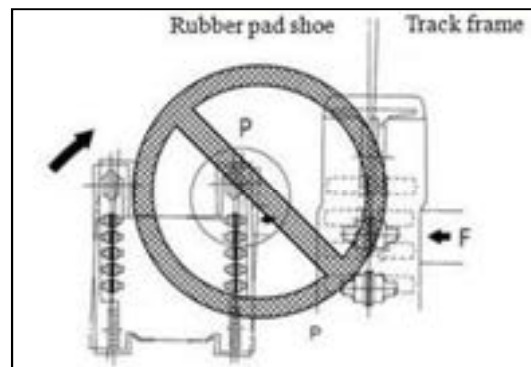

- If machines walking backwards in this case, the rubber pad shoe will fall off.

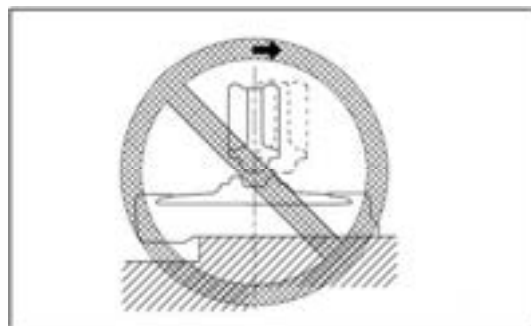

- If machine turns in this case, the rubber pad shoe will fall off.

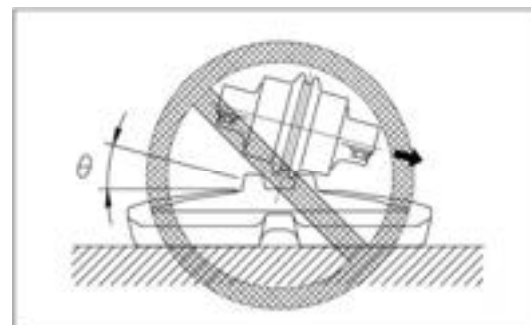

Transportation

When transporting the machine, observe all related laws and regulations, and be careful to assure safety.

Transportation Procedure

Select the method of transportation to match the weight and dimensions given in “Specifications”. Note that the weight and dimensions given in “Specifications” may differ according to the type of shoe or arm, or other attachments.

Loading and Unloading with Trailer



- Select firm, level ground when loading or unloading the machine. Maintain a safe distance from the edge of the road.
- Always turn the auto-deceleration switch OFF (cancel). If the auto-deceleration switch is left ON, the machine may suddenly start moving.
- Always set the travel speed switch to low speed (Lo), run the engine at low idling, and operate the machine slowly when loading or unloading.
- In cold areas, carry out the warming-up operation thoroughly and make sure that the engine speed is stable before carrying out the loading or unloading operation.
- Use ramps with ample width, length, thickness, and strength and install them at a maximum slope of 15°.
When using piled soil, compact the piled soil fully and prevent the slope face from collapsing.
- Remove all mud and dirt from the machine tracks before starting in order to prevent the machine from slipping on the ramps.
Be sure that the ramp surface is clean and free of water, snow, grease, oil, or ice.
- Never correct your steering on the ramps. There is a hazard that the machine may turn over. If necessary, drive off the ramps, correct the direction, then enter the ramps again.
- It is dangerous to use the work equipment for loading and unloading operations.
- It is dangerous to use the work equipment for loading and unloading operations.
- The center of gravity of the machine will change suddenly at the joint between the ramps and the track or trailer, and there is a hazard of the machine losing its balance. Travel slowly over this point.
- When swinging the upper structure on the trailer, the trailer is unstable, pull in the work equipment and swing slowly.
- Position a flagman to give guidance to prevent the machine from coming off the ramps and to ensure safety in the operation.

When loading or unloading, always use ramps or a platform. Proceed as follows.

Loading

1. Load and unload on firm level ground only, maintain a safe distance from the edge of a road.
2. Apply the trailer brakes securely, then put blocks ① under the tires to prevent the trailer from moving. Set left and right ramps ② parallel to each other and equally spaced to the left and right of center ③ of the trailer. Make angle of installation ④ a maximum of 15°.

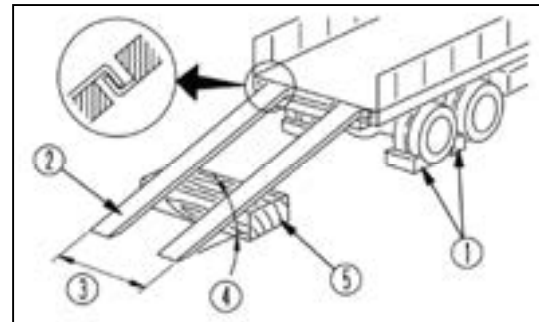

3. Operate the fuel control dial to position (A) to set the engine speed to low idling.

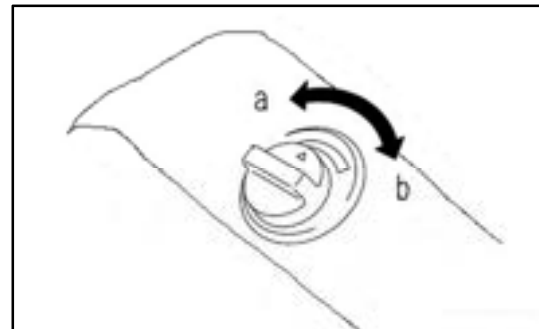

4. Turn the travel speed selector switch to low speed travel.

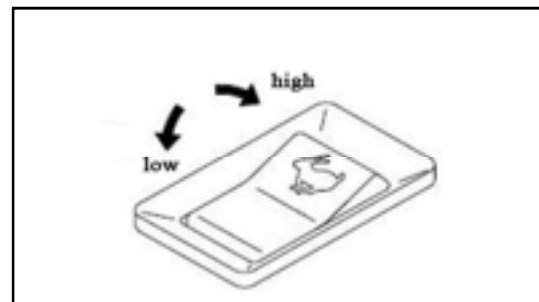

5. If the machine is equipped with work equipment, set the work equipment at the front and blade at the behind. Make sure that rise to the blade and the machine is positioned in a straight line with the ramps and that the centerline of the machine matches that of the trailer.

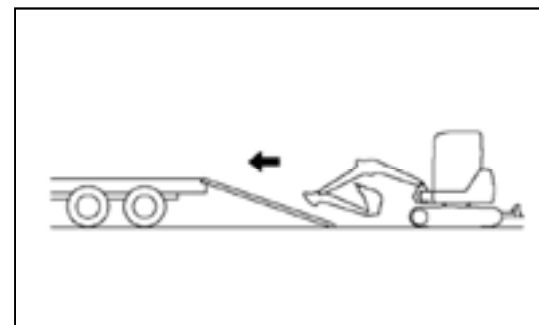

6. Before moving onto the ramps, make sure that the machine is positioned in a straight line with the ramps and that the centerline of the machine matches that of the trailer. Align the direction of travel with the ramps and travel slowly. Lower the work equipment as far as possible without causing interference.

7. When on the ramps, operate only the travel lever. Do not operate any other lever. Drive the machine forward to the specified position, then stop the machine. Then swing the upper structure slowly 180°.
8. Stop the machine at the specified position on the trailer.

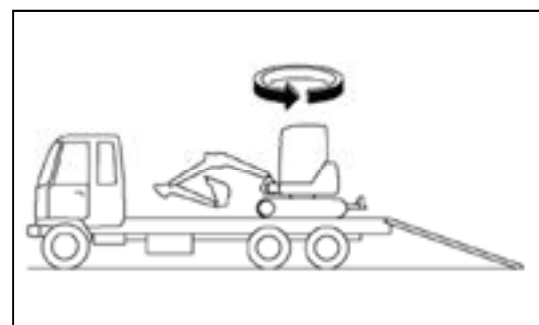

Securing Machine

IMPORTANT

- To prevent damage to the bucket cylinder during transportation, put a wooden block under the tip of the bucket link to prevent the bucket cylinder from touching the floor.

Load the machine onto a trailer as follows:

1. Lower the blade.
2. Extend the bucket and arm cylinders fully, then lower the boom slowly.
3. Set the lock lever securely to the LOCK position (L).

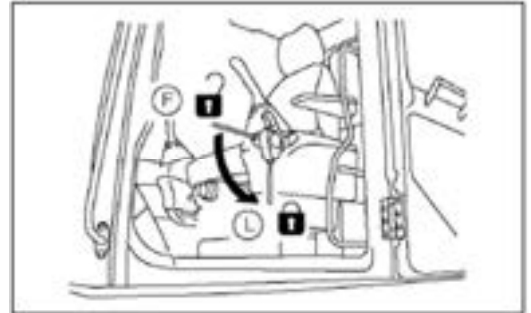
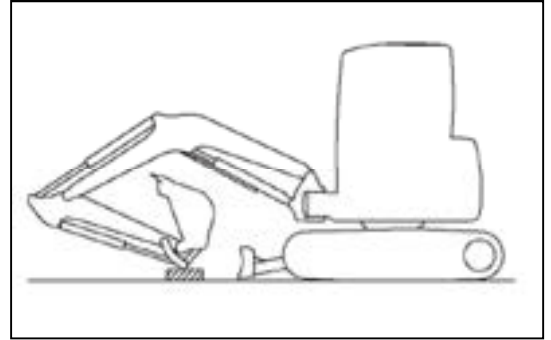

4. Stop the engine, then remove the key from the starting switch.
5. Close all doors, windows, and covers. Lock the covers, caps, and doors fitted with locks.

IMPORTANT

Do not use the holes for fixed at the rear of the track frame for traction, also don't use it to lifting machines and so on.

6. Place blocks under both ends of the tracks to prevent the machine from moving during transportation, and secure the machine with chains or wire rope of suitable strength. Be particularly careful to secure the machine in position so it does not slip to the side.

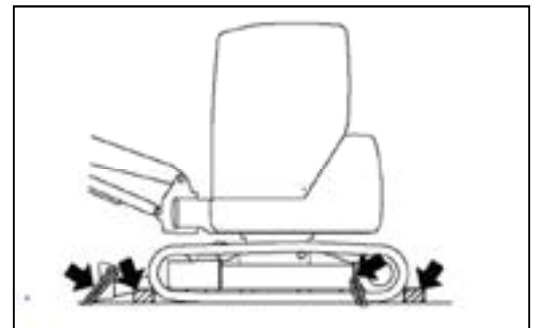

Unloading

1. Load and unload on firm level ground only. Maintain a safe distance from the edge of a road.
2. Apply the trailer brakes securely, then put blocks (1) under the tires to prevent the trailer from moving. Set left and right ramps (2) parallel to each other and equally spaced to the left and right of center (3) of the trailer. Make angle of installation (4) a maximum of 15°. If the ramps bend a large amount under the weight of the machine, put blocks under the ramps to prevent them from bending.
3. Remove the chains and wire ropes fastening the machine.
4. Start the engine. Warm the engine up fully.

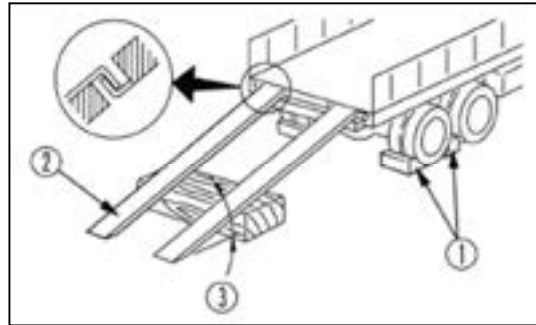

5. Turn the travel speed selector switch to low speed travel.

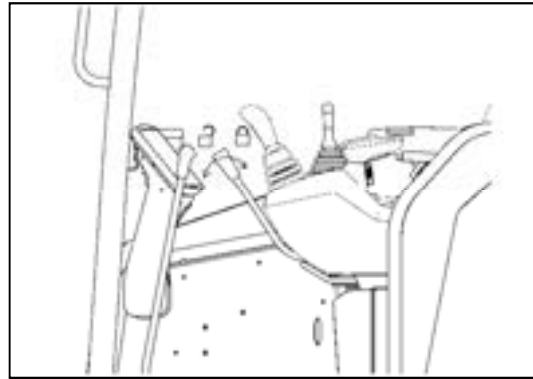

6. Set the lock lever to FREE position.

7. Operate the fuel control dial to (A) to set the engine speed to low idling.
8. Raise the blade.

9. Raise the work equipment, pull in the arm under the boom, and rise to blade, then move the machine slowly. When the machine is horizontal on top of the rear wheels of the trailer, stop the machine. When on the ramps, operate only the travel lever. Do not operate any other lever.

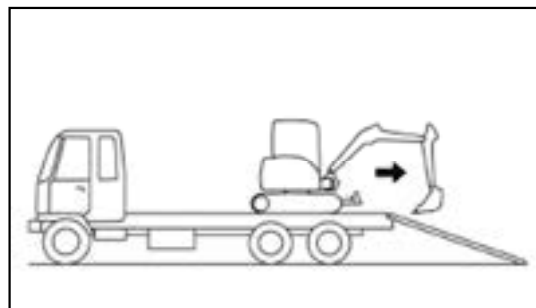

Cold Weather Operation

Cold Weather Operation Information

If the temperature becomes low, it becomes difficult to start the engine, and the coolant may freeze, so do as follows:

Fuel and Lubricants

Change to fuel and oil with low viscosity for all components. For details of the specified viscosity, see "Please use the Recommended Fuel, Oil and Coolant and Water for Dilution".

Cooling System Coolant

WARNING

- Antifreeze is toxic. Be careful not to get it into your eyes or on your skin. If it should get into your eyes or on your skin, wash it off with large amounts of fresh water and see a doctor at once.
- When changing the coolant or when handling coolant containing antifreeze that has been drained when repairing the radiator, please contact your CFG distributor or request a specialist company to carry out the operation. Antifreeze is toxic. Do not let it flow into drainage ditches or spray it onto the ground surface.
- Antifreeze is flammable. Do not bring any flame close. Do not smoke when handling antifreeze.

NOTICE

- Use CFG coolant wherever available
- Never use methanol, ethanol, or propanol-based antifreeze.
- Do not use any water leakage prevention agent, either alone, or in combination with antifreeze.
- Do not mix one brand of antifreeze with a different brand.
- When using CFG coolant, there is no need to use a corrosion resistor.

For details of the antifreeze mixture when changing the coolant, see "Clean inside of Cooling System – Clean/Replace".

Battery

⚠ WARNING

- The battery generates flammable gas. Do not bring fire or sparks near the battery.
- Battery electrolyte is dangerous. If it gets in your eyes or on your skin, wash it off with a large amount of water and consult a doctor.
- Battery electrolyte dissolves paint. If it gets on the bodywork, wash it off immediately with water.
- If the battery electrolyte is frozen, do not charge the battery or start the engine with a different power source. There is danger that the battery may explode.
- Battery electrolyte is toxic. Do not let it flow into drainage ditches or spray it on to the ground surface.

When the ambient temperature drops, the capacity of the battery will also drop. If the battery charge ratio is low, the battery electrolyte may freeze. Maintain the battery charge as close as possible to 100%. Insulate it against cold temperature to ensure the machine can be started easily the next morning.

- As the battery capacity drastically drops in low temperatures, cover or remove the battery from the machine, store the battery in a warm place, and install it again the next morning.

After Daily Work Completion

⚠ WARNING

- Performing idle-running of the tracks is dangerous, stay well away from the tracks.
- After work completion, fill the fuel tank to capacity. This minimizes moisture condensation in the tank when the temperature drops.

To prevent mud, water, or the undercarriage from freezing and making it impossible for the machine to move on the following morning, observe the following precautions.

- Remove all the mud and water from the machine body. In particular, wipe the hydraulic cylinder rods clean to prevent damage to the seal caused by mud, dirt, or drops of water on the rod from getting inside the seal.
- Park the machine on hard, dry ground.
If this is impossible, park the machine on boards.
The boards prevent the tracks from freezing to the ground, and allow the machine to be moved the next morning.
- Open the drain valve and drain any water collected in the fuel system to prevent it from freezing.
- After operation in water or mud, remove water from undercarriage as described below to extend undercarriage service life.
 1. Swing 90° with engine at low idle and bring the work equipment to the side of the track.
 2. Jack up the machine until the track is raised slightly from the ground. Rotate the track under no load.
Repeat this procedure on both the left and right sides.

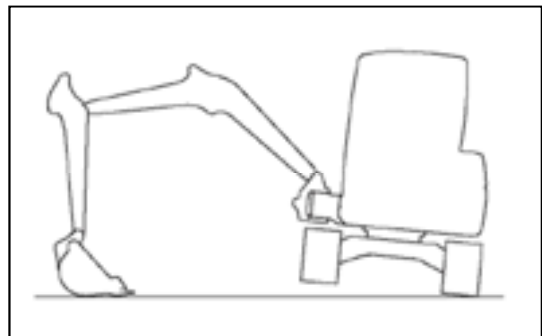

After Cold Weather Season

When the season changes and the weather becomes warmer, do as follows.

- Replace the fuel and oil for all parts with oil of the viscosity specified.
For details, see [“Please use the Recommended Fuel, Oil and Coolant and Water for Dilution”](#).
- If for some reason it is not possible to use permanent type coolant, replace it with

- glycol-based coolant, or if there is no coolant, must clean the cooling system completely, and add fresh soft water.

Long Term Storage

Before Storage

NOTICE

When storing the machine (1 month or more), set the machine in the posture shown in the diagram on the right to protect the cylinder rod. (To prevent rusting of the cylinder rod).

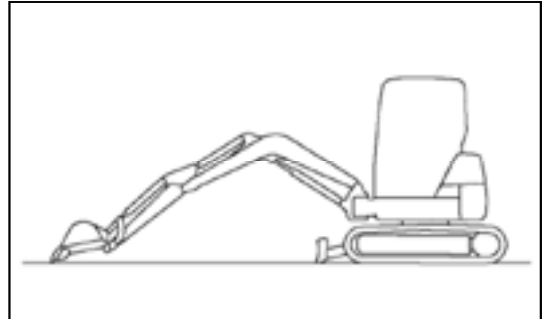

When putting the machine in storage for a long time (more than one month), do as follows.

- Clean and wash all parts, then store the machine indoors. If the machine has to be stored outdoors, select level ground and cover the machine with canvas.
- Completely fill the fuel tank. This prevents moisture from collecting.
- Lubricate and change the oil before storage.
- Coat the exposed portion of the hydraulic cylinder piston rod with grease.
- Disconnect the negative terminals of the battery and cover it or remove it from the machine and store it
- Set the attachment control pedal to the lock position on machines ready for attachments.
- Set the stop valve to the LOCK position on machines ready for attachments. Install the blind plugs to the elbows.

During Storage

⚠ WARNING

If it is necessary to perform the rust-prevention operation while the machine is indoors, open the doors and windows to improve ventilation and prevent gas poisoning.

- During storage, operate and move the machine for a short distance once a month so that a new film of oil will coat moving parts. At the same time, also charge the battery.
- When operating the work equipment, wipe off all the grease from the hydraulic cylinder rods.
- If the machine is equipped with an air conditioner, operate the air conditioner for 3 to 5 minutes once a month to lubricate all parts of the air conditioner compressor. Always run the engine at low idle when doing this. In addition, check the refrigerant level twice a year.

After Storage

NOTICE

If the machine has been stored without carrying out the monthly rust-prevention operation, consult your CFG construction machinery distributor before using it.

When using the machine after long-term storage, do as follows before using it.

- Wipe off the grease from the hydraulic cylinder rods.
- Add oil and grease at all lubrication points.
- When the machine is stored for a long period, moisture in the air will mix with the oil. Check the oil before and after starting the engine. If there is water in the oil, change all the oil.
- Turn on the battery circuit breaker. The operation method refers to "battery circuit breaker".

Troubles and Actions

Running out of Fuel

When starting the engine again after running out of fuel, fill with fuel, then bleed the air from the fuel system before starting the engine.

For details, see [“Air Bleeding of Fuel System”](#)

Phenomena that are not Failures

Note that the following phenomena are not failures:

- When the arm control lever is operated to the IN position and the work equipment is lowered under no load from a high position, the arm speed will drop momentarily when the arm is more or less at the vertical position.

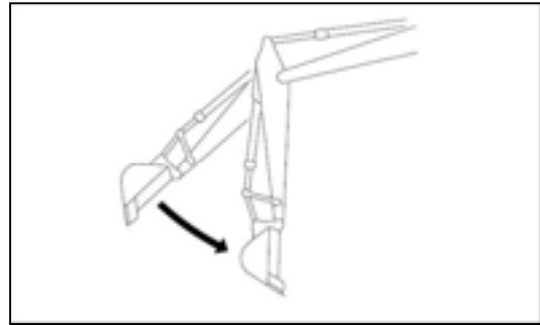

- When the bucket control lever is operated to the CURL position and the work equipment is lowered under no load from a high position, the bucket speed will drop momentarily when the bucket teeth are more or less at the horizontal position. The bucket or arm will fluctuate by itself during heavy-duty digging operations.

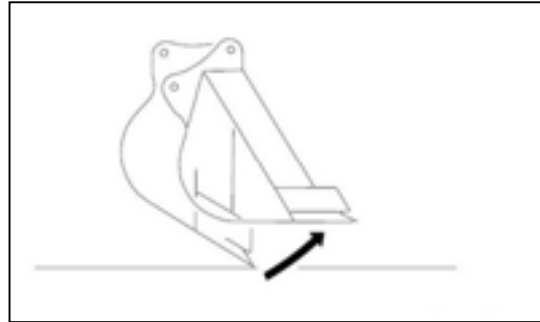

- When starting or stopping the swing, noise will be emitted from the brake valve.
- When going down a steep slope at low speed, a noise will be emitted from the travel motor brake valve.

Towing the Machine

WARNING

- Always check that the wire rope used for towing has ample strength for the weight of the machine being towed.
- Operate the machine slowly and be careful not to apply any sudden load to the wire rope.

If the machine sinks in mud and cannot get out under its own power, or if the drawbar pull of the excavator is being used to tow a heavy object, use a wire rope as shown in the diagram on the right. Place pieces of wood between wire ropes and body to prevent damage to ropes and body. Hold the wire rope level and direct it straight to the track frame.

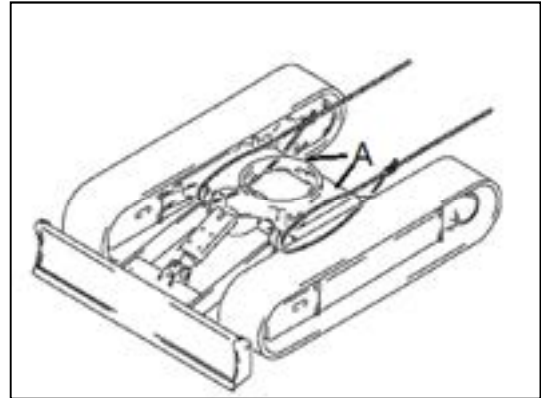

Lightweight Towing Hole

WARNING

- When use A hook rings (1), the traction load must be light, otherwise it is easy to damage the crawler frame.
- Hold the wire rope level and direct it straight to the track frame.
- Move the machine slowly and be careful not to apply any sudden load to the wire rope.

There is one hole in the track frame to fit the shackle when towing light objects.

Severe Job Condition

- When carrying out digging operations in water, if the work equipment mounting pin goes into the water, carry out greasing at the position (A)、(B)、(C)、(D) and E every time the operation is carried out.
- For heavy-duty operations and deep digging, carry out greasing of the work equipment mounting pins (A)、(B)、(C)、(D) and (E) every time before operation.

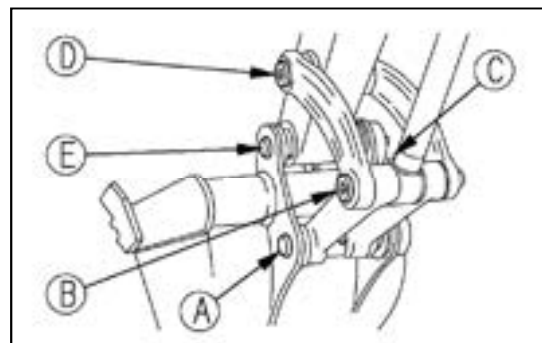

After greasing, operate the boom, arm and bucket several times, then grease again.

Battery Discharges and Charges

WARNING

- It is dangerous to charge a battery when mounted on a machine. Make sure that it is dismantled before charging.
- When checking or handling the battery, stop the engine and turn the starting switch key to the OFF position.
- The battery generates hydrogen gas, so there is a hazard of explosion. Do not bring lighted cigarettes near the battery, or do anything that will cause sparks.
- When handling batteries, always wear safety glasses and rubber gloves.
- Battery electrolyte is dilute sulfuric acid, and it will attack your clothes and skin. If it gets on your clothes or on your skin, immediately wash it off with a large amount of water. If it gets in your eyes, wash it out with fresh water and consult a doctor.
- When removing the battery, first disconnect the cable from the ground (normally the negative (-) terminal). When installing, install the positive (+) terminal first. If a tool touches the positive terminal and the chassis, there is danger that it will cause a spark, so be extremely careful.
- If the terminals are loose, there is danger that the defective contact may generate sparks that will cause an explosion.
- When removing or installing the terminals, check which is the positive (+) terminal and which is the negative (-) terminal.

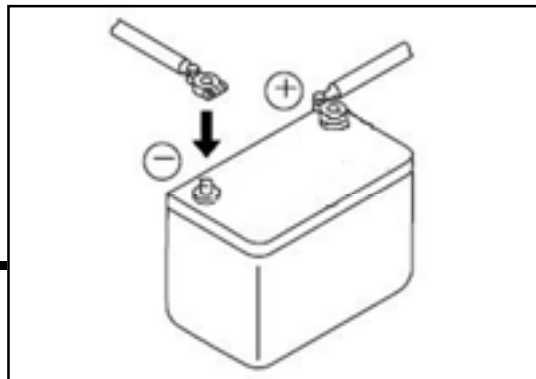
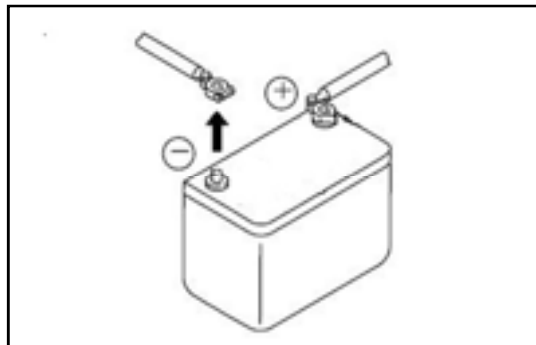
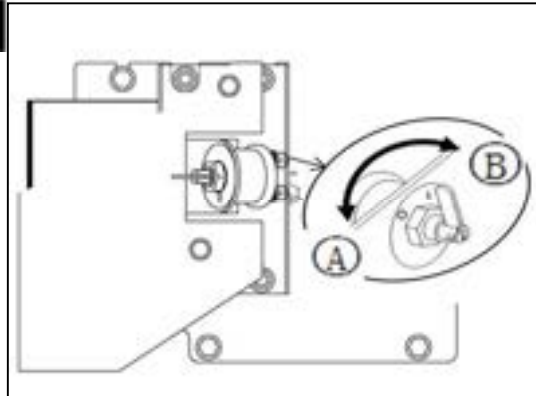

Battery Removal and Installation

NOTICE

After installing the battery in place, check whether the battery is moving. If moving and re-tighten it.

- Open the left hood.
- When removing the battery, first disconnect the cable from the ground (normally the negative (-) terminal).
If a tool touches the positive terminal and the chassis, there is danger that it will cause a spark, so be extremely careful.
- Then remove four nuts and two screws, you can remove the battery.
- When installing the battery, connect the ground cable last.
- When replacing the battery, secure it with battery hold-down.

Additional Electric Battery

Before cars started, the car with electric start time is too long and abnormal use, because of leakage and long car stops, the vehicle or the vehicle charging generator failure, the battery can't normal charging battery loss caused by electricity, battery electric eye blackened, even can't start the car. The battery need to supplement by electricity.

Check the battery status indicator (wink), power display:

Green: the battery power is enough, can normal boot excavator.

Black: deficiency of battery, the battery should be added.

White: battery needs replacement.

1. nce inspection before charging

- Do not charge the battery if the shell burst or it leaks acid, replace the battery after finding out the reason.
- Do not charge the battery if its end column burst, replace the battery after finding out the reason.
- Do not charge the battery if the electric eye is white and replace the battery
Do not charge the inflation bulging battery caused by over-discharge or overcharge and replace the battery
- Clean the end column and remove the surface scale before charge the battery.

2. When charging the battery we must know

- Wearing glasses.
- Maintain environmental ventilation when charging, charging under normal temperature.
- No smoking when charging, and avoid the introduction of the flame.
- After charging connection, first connect the positive attachment; Take out stitches before charging, disconnect the cathode attachment first.

3. Battery charging

- Connect the positive (+) charger clip of the charger to the positive (+) terminal of the battery, then connect the negative (-) charger clip of the charger to the negative (-) terminal of the battery.
- Make sure the battery is clean and the charging circuit is well connected.
- Recommended use constant voltage 16.0 volts (maximum can not exceed 16.2 volts, the charging current does not exceed 25A) charger to charge battery until the electric eye turns green. The battery is fully charged when the eye turns green.
- IF there is not a constant voltage way to charge, according to the following specifications constant current charging:
- Charging current(A)=C20/10. (C20 --- 20 hours rate capacity)

Note: If more than one battery is charged in parallel, the current values are summed.

Charging time and battery voltage corresponding relationship (reference)

Battery voltage	12.55 ~12.4 5V	12.45 ~12.3 5V	12.35 ~12.2 0V	12.20 ~12.0 5V	12.05~ 11.95V	11.95~ 11.80V	11.80~ 11.65V	11.65~ 11.50V	11.50 ~11.30 V	11.30~ 11.00V	bellow 11.00V
Charging time	2 hours	3 hours	4 hours	5 hours	6 hours	7 hours	8 hours	9 hours	10 hours	12 hours	14 hours

- After charging, check the color of the accumulator's eye. The electro-optic display is green, indicating that the battery is fully charged. If the eye is black, check whether the charging connection is secured, whether the connection point is clean, and continue to replenish the electricity until the eye appears green. For batteries whose battery voltage is less than 11.0V, the phenomenon of battery charging out may occur in the initial stage of replenishment. Because of the serious shortage of batteries, the proportion of sulfuric acid in the batteries has approached pure water, and the internal resistance of the batteries is very large. With the charging of the batteries, the proportion of sulfuric acid in

the batteries increases, and the charging current of the batteries can gradually return to normal.

- During charging process, if the battery exhaust hole vent acid, should stop charging immediately.
- During charging process, check the battery eye color every hour. The battery is fully charged when the eye turns green, then stop charging.

Starting Engine with Booster Cables

When starting the engine with a booster cable, do as follows:

Connecting and Disconnecting Booster Cables

WARNING

- When connecting the cables, never contact the positive (+) and negative (-) terminals.
- When starting the engine with a booster cable, always wear safety glasses.
- Be careful not to let the normal machine and problem machine contact each other. This prevents sparks from generating near the battery which could ignite the hydrogen gas given off by the battery. If hydrogen gas explodes, it could cause serious injury.
- Be careful not to make a mistake when connecting a booster cable. In the last connection (to the upper structure frame), a spark will be caused, connect the cable to a spot as far away from the battery as possible. (Avoid the work equipment, however, because it is not a good conductor)
- When removing the booster cable, exercise good care so that the booster cable clips may not contact each other, or they contact the chassis.

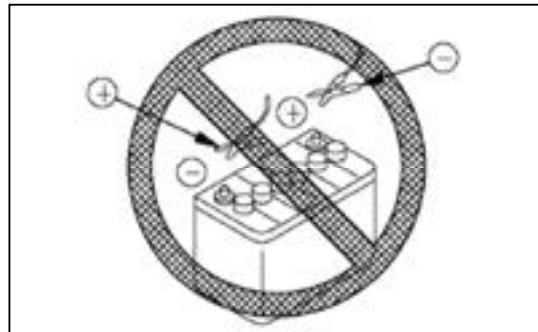

NOTICE

- The starting system for this machine uses 12V. For the normal machine, also use a 12V battery.
- The size of the booster cable and clip should be suitable for the battery size.
- The battery of the normal machine must be the same capacity as that of the engine to be started.
- Check the cables and clips for damage or corrosion.
- Make sure that the cables and clips are firmly connected.
- Check that the lock levers and parking brake levers of both machines are in the LOCK position.
- Check that each lever is in the NEUTRAL position.

Booster Cable Connection

Keep the starting switch of the normal machine and problem machine in the OFF position.

1. Connect the booster cable as follows, in the order of the numbers marked in the diagram.
2. Connect the clip of booster cable (A) to the positive (+) terminal of battery on the problem machine.
3. Connect the clip at the other end of booster cable (A) to the positive (+) terminal of battery on the normal machine.

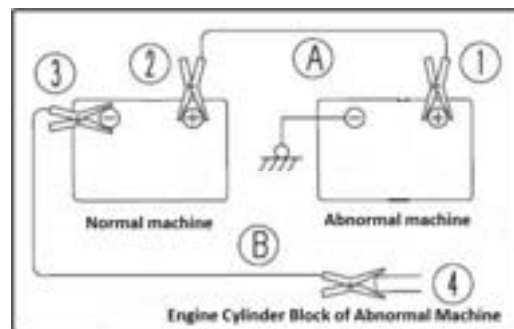

4. Connect the clip of booster cable (B) to the negative (-) terminal of battery on the normal machine. Connect the other clip of booster cable (B) to the revolving frame of the problem machine.

Others Malfunction

Chassis

- In case of problems or causes which are not listed below, contact your CFG distributor.

Problem	Main causes	Remedy
Speed of travel, swing, boom, arm, bucket is low	□ Lack of hydraulic oil	□ Add oil to specified level, see Maintenance
Pump generates abnormal noise	□ Clogged element in hydraulic	□ Clean, see Maintenance
Excessive rise in hydraulic oil temperature	□ Loosen fan belt □ Dirty oil cooler □ Lack of hydraulic oil	□ Check and adjust fan belt tension, see Maintenance □ Clean, see Maintenance □ Add oil to specified level, see Maintenance
Track comes off Abnormal wear of sprocket	□ Track too loose	□ Adjust track tension, see Maintenance
Boom rises slowly, does not rise	□ Lack of hydraulic oil	□ Add oil to specified level, see Maintenance

Electrical System

- When dealing with these projects, please contact the CFG dealer.
- If there are not listed in the table below the fault or reason, please contact the dealer for repair.

Hitch	Main cause	Redolent
Even if the engine is running at high speed, the lighting is not bright.	□ Lead failure □ Belt tension adjustment error	□ (Check and repair the loose terminals.)
When the engine is running, the lights flicker		□ Adjust fan belt tension, see every 1000 hours of maintenance
Even when the engine is running, the charge monitor does not go out.	□ AC generator fault □ Lead failure	□ (replace) □ (Check and repair)
AC generator generates abnormal noise	□ AC generator fault	□ (replace)
When the starting switch is switched to ON, the starting motor does not work.	□ Lead failure □ Starting motor fault □ Battery charging problem □ Safety relay fault	□ (Check and repair) □ (replace) □ Charge □ (replace)
Starting motor pinion to keep running	□ Battery charging problem □ Starting motor fault	□ Charge □ (replace)
Start motor slowly rotating engine	□ Battery charging problem □ Starting motor fault	□ Charge □ (replace)
Before starting the engine, motor starting off	□ Lead failure □ Battery charging problem	□ Check and repair □ Charge

Engine

- Always contact your CFG distributor when dealing with these items.
- In cases of problems or causes which are not listed below, contact your CFG distributor for repairs.

Problem	Main causes	Remedy
Engine oil pressure monitor lights up	<ul style="list-style-type: none"> □ Engine oil pan oil level is low □ (sucking in air) □ Clogged oil filter cartridge □ Defective tightening of oil pipe, pipe joint, oil leakage from damaged point □ Defective engine oil pressure sensor □ Defective monitor 	<ul style="list-style-type: none"> □ Add oil to specified level, see CHECK BEFORE STARTING □ Replace cartridge, see EVERY 500 HOURS SERVICE □ (Check, repair) □ (Replace)
Steam spurts out from top of radiator (pressure valve)	<ul style="list-style-type: none"> □ Coolant level low, leakage of water □ Dirt or scale accumulated in cooling system □ Clogged radiator fins or damaged fins □ Defective thermostat □ Loose radiator filler cap (high-altitude operations) □ Defective water level sensor 	<ul style="list-style-type: none"> □ Check, add coolant, repair □ Change coolant, flush inside of cooling system, (Replace thermostat) □ Tighten cap or replace packing □ (Replace sensor)
Radiator coolant level monitor lights up		
Even after long hours of operation, radiator coolant level monitor lights up	<ul style="list-style-type: none"> □ Defective thermostat 	<ul style="list-style-type: none"> □ (Replace thermostat)
Engine does not start when starting motor is turned	<ul style="list-style-type: none"> □ Lack of fuel □ Air in fuel system □ Defective fuel injection pump or defective nozzle □ Starting motor cranks engine sluggishly □ Engine pre-heating monitor does not light up □ Defective compression 	<ul style="list-style-type: none"> □ Add fuel, see CHECK BEFORE STARTING □ Repair place where air is sucked in □ (Replace pump or nozzle) □ See ELECTRICAL SYSTEM □ See ELECTRICAL SYSTEM □ (Adjust valve clearance)
Exhaust gas is white or blue	<ul style="list-style-type: none"> □ Too much oil in oil pan □ Improper fuel □ Start the engine suddenly accelerated in the cold days 	<ul style="list-style-type: none"> □ Set oil to specified level, see CHECK BEFORE STARTING □ Change to specified fuel □ Avoid suddenly acceleration before the warm-up operation is completed
Exhaust gas occasionally turns black	<ul style="list-style-type: none"> □ Clogged air cleaner element □ Defective nozzle □ Defective compression 	<ul style="list-style-type: none"> □ Clean or replace □ (Replace nozzle) □ (See defective compression above)
Combustion noise occasionally make breathing sound	<ul style="list-style-type: none"> □ Defective nozzle 	<ul style="list-style-type: none"> □ (Replace nozzle)

Abnormal noise generated (combustion or mechanical)	<ul style="list-style-type: none"><input type="checkbox"/> Low-grade fuel being used<input type="checkbox"/> Overheating<input type="checkbox"/> Damage inside muffler<input type="checkbox"/> Excessive valve clearance	<ul style="list-style-type: none"><input type="checkbox"/> Change to specified fuel<input type="checkbox"/> Refer to "Radiator coolant level monitor lights up" as above<input type="checkbox"/> Replace muffler<input type="checkbox"/> (Adjust valve clearance)
The engine stops when operating	<ul style="list-style-type: none"><input type="checkbox"/> Clogged fuel cleaner element<input type="checkbox"/> Defective engine or defective fuel line	<ul style="list-style-type: none"><input type="checkbox"/> Replace<input type="checkbox"/> (Check, repair)

便签页

便签页

MAINTENANCE



WARNING

Please read and make sure that you understand the SAFETY section before reading this section.

Maintenance Information

Do not perform any inspection and maintenance operation that is not found in this manual.

Service Meter Reading

Check the service meter reading every day to see if the time has come for any necessary maintenance to be performed.

Genuine Replacement Parts

Use CFG genuine parts specified in the Parts Book as replacement parts.

CFG Genuine Lubricants

Use CFG genuine oils and grease. Choose oils and grease with proper viscosities specified for ambient temperature.

Fresh and Clean Lubricants

Use clean oil and grease. Also, keep the containers of the oil and grease clean. Keep foreign materials away from oil and grease.

Check Drained Oil and Used Filter

After oil is changed or filters are replaced, check the old oil and filters for metal particles and foreign materials. If large quantity of metal particles or foreign materials are found, always report to the person in charge, and carry out suitable action.

Fuel Strainer

If your machine is equipped with a fuel strainer, do not remove it while fueling.

Welding Instructions

- Cut off power. Wait for approx. one minute after turning off the engine starting switch key, and then disconnect the negative (-) terminal of the battery.
- Do not apply more than 200 V continuously.
- Connect grounding cable within 1 m (3.3 ft) of the area to be welded. If grounding cable is connected near instruments, connectors, etc., the instruments may malfunction.
- If a seal or bearing happens to come between the part being welded and grounding point, change the grounding point to avoid such parts.

NOTE

Do not use the area around the work equipment pins or the hydraulic cylinders as the grounding point.

Do not Drop Things Inside Machine

- When opening inspection windows or the oil filler port of the tank to carry out inspection, be careful not to drop nuts, bolts or tools inside the machine.
- If such things are dropped inside the machine, it may cause damage and/or malfunction of the machine, and will lead to failure. If you drop anything inside the machine, always remove it immediately.
- Do not put unnecessary things in your pockets. Carry only things which are necessary for inspection.

Dusty Jobsite

When working at dusty worksites, do as follows:

- Clean the radiator fins and other parts of the heat exchange equipment more frequently, and take care not to let the fins become clogged.
- Replace the fuel filter more frequently.
- Clean electrical components, especially the starting motor and alternator, to avoid accumulation of dust.
- When checking and replacing the oil or filters, move the machine to a place where there is no dust and take care
- To prevent dust from entering the system.

Avoid Mixing Lubricants

If a different brand or grade of oil has to be added, drain the old oil and replace all the oil with the new brand or grade of oil. Never mix different brand or grade of oil.

Choose fuels and lubricants that match the ambient temperature

Must use fuels and lubricants that match the ambient temperature.

For details, see “Use of Fuels, Coolants and Lubricants according to ambient Temperature”.

Locking the Inspection Covers

Lock inspection cover securely into position with the lock bar. If inspection or maintenance is performed with inspection cover not locked in position, there is a danger that it may be suddenly blow shut by the wind and cause injury to the worker.

Hydraulic System - Air Bleeding

When hydraulic equipment has been repaired or replaced, or the hydraulic piping has been removed and installed again, the air must be bled from the circuit.

Hydraulic Hose Installation

- When removing parts at locations where there are O-rings or gasket seals, clean the mounting surface, and replace with new parts. When doing this, be careful not to forget to assemble the O-rings and gaskets.
- When installing the hoses, do not twist them or bend them sharply. If they are installed so, their service life will be shortened extremely and they may be damaged.

Checks After Inspection and Maintenance Works

If you forget to perform the checks after inspection and maintenance, unexpected problems may occur, and this may lead to serious injury or property damage. Always do the following:

Checks after operation (with engine stopped)

- Have any inspection and maintenance points been forgotten?
- Have all inspection and maintenance items been performed correctly?
- Have any tools or parts been dropped inside the machine? It is particularly dangerous if parts are dropped inside the machine and get caught in the lever linkage mechanism.
- Are there any leakages of coolant or oil? Have all nuts and bolts been tightened?

Checks when operating engine

- For details of the checks when operating the engine, see "Maintenance of the Engine" and pay careful attention to safety.
- Are the inspection and maintenance items working properly? Is there any leakage of fuel or oil when the engine speed is raised?

Lubricants, Fuels and Coolants

Lubricants

- Oil is used in the engine and hydraulic equipment under extremely severe conditions (high temperature, high pressure), and deteriorates with use.
- Always use oil that matches the grade and maximum and minimum ambient temperatures recommended in the Operator's Manual. Even if the oil is not dirty, always change the oil at the specified interval.
- Oil corresponds to blood in the human body, always be careful when handling it to prevent any impurities (water, metal particles, dirt, etc.) from getting in. When storing or adding oil, take special care not to let any impurities in.
- Never mix oils of different grades or brands.
- Always add the specified amount of oil. Having too much oil or too little oil are both causes of problems.
- If the oil in the work equipment is not clear, there is probably water or air getting into the circuit. In such cases, please contact your CFG distributor.
- When changing the oil, always replace the related filters at the same time.
- We recommend you have an analysis made of the oil periodically to check the condition of the machine. For those who wish to use this service, please contact your CFG distributor.
- When using commercially available oil, it may be necessary to reduce the oil change interval.

Fuel

- The fuel pump is a precision instrument, and if fuel containing water or dirt is used, it cannot work properly.
- Be extremely careful not to let impurities get in when storing or adding fuel.
- Always use the fuel specified for the temperature in the Operator's Manual.
- If the fuel is used at temperatures lower than the specified temperature (particularly at temperatures below -15°C (5°F), the fuel will solidify.
- To prevent moisture in the air from condensing into water in the fuel tank, fill the fuel tank at the end of each day's work.
- Before starting the engine, or when 10 minutes have passed after adding fuel, drain the sediment and water from the fuel tank.
- If the engine runs out of fuel, or if the filters have been replaced, it is necessary to bleed the air from the circuit.

Storing Oil and Fuel

- Keep indoors to prevent any water, dirt, or other impurities from getting in.
- When keeping drum cans for a long period, put the drum on its side so that the filler port of the drums is at the side to prevent moisture from being sucked in.
- If drums have to be stored outside, cover them with a waterproof sheet or take other measures to protect them.
To prevent any change in quality during long-term storage, be sure to use in the order of first in - first out (use the oldest oil or fuel first).

Grease

- Grease is used to prevent seizure and noises at the joints.
- This construction equipment is used under heavy-duty conditions. Always use the recommended grease and follow the change intervals and recommended ambient temperatures given in this Operator's Manual.
- The nipples not included in the maintenance section are nipples for overhaul, so they do not need grease. If any part becomes stiff after being used for long time, add grease. If any part becomes stiff after being used for long time, add grease.
- Always wipe off all of the old grease that is pushed out when greasing.
- Always wipe off all of the old grease that is pushed out when greasing.

Be particularly careful to wipe off the old grease in places where sand or dirt sticking in the grease would cause wear of the rotating parts.

Coolant of the cooling system

- When diluting the antifreeze coolant, use distilled water or tap water (soft water). Natural water, such as a river water or well water (hard water), contains large amounts of minerals (calcium, magnesium, etc.), and this makes it easier for scale to form inside the engine or radiator. Once scale is deposited inside the engine or radiator, it is extremely difficult to remove. It also causes overheating due to poor heat exchange.
- When using antifreeze, always observe the precautions given in the Operation and Maintenance Manual.
- CFG machines are supplied with CFG Coolant. CFG Coolant has excellent anticorrosion, antifreeze and cooling properties and can be used continuously for 2 years or 3000 hours. This antifreeze can be used even in hot areas.
- Antifreeze coolant is flammable, so be sure to keep it away from flame.
- The ratio of coolant to water differs according to the ambient temperature.
- If the engine overheats, wait for the engine to cool before adding coolant.
- If the coolant level is low, it will cause overheating, and will also cause problems with corrosion due to air entering the coolant.

Filters

- Filters are extremely important safety parts. They prevent impurities in the fuel and air circuits from entering important equipment and causing problems. Replace all filters periodically. For details, refer to the operation and maintenance manual.
- However, when working in severe conditions, replace the filters at shorter intervals according to the oil and fuel (sulfur content) being used.
- Never try to clean the filters (cartridge type) and use them again. Always replace with new filters.
- When replacing oil filters, check if any metal particles are attached to the old filter. If any metal particles are found, contact your CFG distributor.
- Do not open packs of spare filters until just before they are to be used.
- Always use CFG genuine filters.

Electric System Maintenance

- It is extremely dangerous if the electrical equipment becomes wet or the covering of the wiring is damaged. This will cause an electrical short circuit and may lead to malfunction of the machine. Do not wash the inside of the operator's cab with water. When washing the machine, be careful not to let water get into the electrical components.
- Service relating to the electric system is checking fan belt tension, checking damage or wear to the fan belt and checking battery fluid level.
- Never install any electric components other than those specified by CFG.

- External electron-magnetic interference may cause malfunction of the control system
-
- controller, before installing a radio receiver or other wireless equipment, contact your
- CFG distributor.
- When working at the seashore, carefully clean the electric system to prevent corrosion.
- When installing electrical equipment, connect it to the special power source connector.
- Do not connect the optional power source to the fuse, starting switch, or battery relay.

Maintenance of Hydraulic System

- The hydraulic device is in high temperature during and after operation. In addition, due to the high pressure in the process of operation, the following matters should be noted during the inspection and maintenance of the hydraulic device:
- Leave the machine in a flat place so that the bucket is completely lowered to the ground, and check and maintain it without pressure applied to the oil path of the cylinder.
- Be sure to stop the engine
- After the operation, the hydraulic oil and lubricating oil are still in the state of high temperature and high pressure, and the maintenance can only be carried out after the oil temperature of each part drops.
- Sometimes even though the temperature has dropped, the internal pressure is still there. The internal pressure should be released before maintenance. At the same time, slowly loosen the screw plug, screw and screw loose pipe joint, avoid the front of the body, and remove it while releasing internal pressure.
- During the inspection and maintenance of the hydraulic oil circuit, please be sure to discharge the air in the hydraulic tank and release the internal pressure.
- Inspection and maintenance includes inspection of hydraulic oil level, filter and replacement of hydraulic oil. When removing the high pressure hose, be careful not to damage the o-ring. If there is any damage, please replace it.
- When replacing and cleaning the filter element and screen of the hydraulic oil filter, when repairing, replacing and removing the hydraulic piping of the hydraulic device, air shall be discharged from the oil path.

Wear Parts

- Replace wear parts such as the filter element or air cleaner element at the time of periodic maintenance or before they reach the wear limit.
- The wear parts should be replaced correctly in order to ensure more economic use of the machine.
- When ordering parts, check the part number in the parts catalog.

Wear Parts List

(The parts in parentheses are to be replaced at the same time)

Item	Part No.	Part Name	Q'ty	Replacement frequency
Engine oil filter	60025-03-00007	Water filter element	1	Every 250 hours
Fuel filter	60025-78-00006	Hydraulic return filter	1	Every 1000 hours
	60025-78-00005	Hydraulic suction filter	1	Every 2000 hours
	60025-78-00007	Preloaded air filter	1	Every 2000 hours
Fuel filter	60025-03-00006	Fuel pre-filter element	1	Every 500 hours
	60025-03-00005	Fuel oil fine filter	1	
Guide cartridge	60070-84-00165	Guide cartridge	1	First 500 hours, every 1000 hours
Air cleaner	60017-07-00005	Main element	1	After six times every 1000 hours
	60017-07-00004	Safety element	1	
Bucket	60025-63-00018	Tooth	3	—
	60025-63-00020	Jump ring	3	
	60025-63-00021	pin	3	
	60025-63-00017	Left edge blade	1	—
	60025-63-00016	right edge blade	1	
Plow	60025-53-00005	Knife plate (welding)	1	—

Notice: Actual replacement frequency accord to Maintenance schedule.

Use the Recommended Fuel, Coolant and Lubricants

- In order to maintain the reliability and durability of CFG products and their parts, please use CFG pure oil. Please buy pure oil from CFG or CFG appointed agency to ensure the oil quality.
- Failure to use the recommended product can result in shortened life and excessive wear of engines, drivetrains, cooling systems and other components.
- Select and use the oils and grades recommended in the table below according to ambient temperature.
- Under 0 °C when you start the engine, even if the temperature has risen to more than 0 °C temperature, also be sure to use more than the recommended grade engine oil.
- When refueling, the filter should be removed from the refueling port first, and then be cleaned with clean diesel oil and put back to the refueling port before refueling.
- The addition of oil and grease should meet the requirements, not too much or too little.
- The appliance that refuels, water must be clean, store in the box that covers tightly after using or cabinet.
- When the discharge of oil will make the oil temperature preheating to 30 ~ 40 °C advisable

Correct Selection

Location	Species	Ambient temperature									
		-22	-4	14	32	50	68	86	104	122° F	
		-30	-20	-10	0	10	20	30	40	50° C	
Engine lubrication	Engine oil	SAE 10W									
		SAE 10W-30									
		SAE 15W-40									
		SAE 30									
		SAE 40									
Hydraulic tank	Mineral oil	ISO VG46									
		ISO VG68									
Swing drive	Gear oil	SAE 85W-140 or API GL-5									
Travel drive	Gear oil	SAE 80W-90 or API GL-5									
Fuel tank	Diesel fuel	-35#									
		-10#									
		0# or 5#									
Grease fitting	Grease	Molybdenum disulfide NLG12									
Cooling system	Antifreeze	-45#									
		-35#									
		-20#									

Please buy genuine oil from distributor, in order to ensure the quality of oil.

Notice:

SAE: Society of Automotive Engineers

ISO: International Organization for Standardization

API: American Petroleum Institute

Tightening Torque Specifications



- If nuts, bolts, or other parts are not tightened to the specified torque, it will cause looseness or damage to the tightened parts, and this will cause failure of the machine or problems with operation.
- Always pay careful attention when tightening parts.

Unless otherwise specified, tighten the metric nuts and bolts to the torque shown in the table below.

If it is necessary to replace any nut or bolt, always use a CFG genuine part of the same size as the part that was replaced.

Tightening Torque List

Thread diameter	Across flats S/mm	Tightening torque: [N·m (Kgf·m)]	
		Extent	Target
M6	10	11.8 ~ 14.7	13.2
M8	13	27 ~ 34	31.4
M10	16	59 ~ 74	65.7
M12	18	98 ~ 123	112.7
M14	21	157 ~ 196	176
M16	24	245 ~ 309	279
M18	27	343 ~ 427	382
M20	30	490 ~ 608	549
M22	34	662 ~ 829	745
M24	36	824 ~ 1030	927
M27	41	1180 ~ 1470	1323

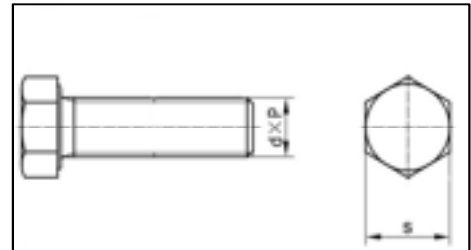

Apply the following table for Hydraulic Hose:

Nominal number	Thread Diameter M	Width across Flats S	N·m	
			Target value	Extent
L ^a	M12X1.5	14	16	15-17
	M14X1.5	17	16	15-17
	M16X1.5	19	26	25-28
	M18X1.5	22	37	35-39
	M22X1.5	27	47	45-50
	M26X1.5	32	89	85-94
S ^a	M22X1.2	27	79	75-83
	M24X1.5	30	84	80-88

Notice:

L^a: Light series connector, S^a: Heavy series connector, see ISO8434-1 for the distinction of weight series.

Regular Replacement of Safety Critical Parts

- To ensure safety, the user must perform regular maintenance on the machine when operating or driving the machine. In addition, in order to further improve safety, users should also periodically replace parts in the safety critical parts list. These parts have a particularly close relationship to safety and fire protection, so please contact your CFG for replacement.
- For these parts, the material changes over time and they are prone to wear or deterioration. However, it is difficult to completely judge the condition of the parts through regular maintenance. Therefore, the specified time is up, regardless of the situation, it must be replaced. This is necessary to ensure that these parts always maintain their function completely.
- If these parts have not returned to the replacement cycle, they must be repaired or replaced immediately.
- If the hose clamp deteriorates, such as deformation or cracks, replace the hose clamp while replacing the hose.
- The following checks should be performed on hydraulic hoses that are not listed as regular replacement parts. If abnormalities are found, tighten or replace them.
- When replacing the hose, replace the O-ring, gasket and other similar parts at the same time.

Safety critical parts

Number	Part Name	Q'ty	Replacement frequency
1	Fuel hose (fuel tank - fuel pre-filter)	1	Every 2 years or 3000 hours, whichever comes first
2	Fuel hose (fuel pre-filter - fuel fine filter)	1	
3	Fuel hose (fuel fine filter - engine)	1	
4	Fuel return pipe (engine - fuel tank)	1	
5	Hydraulic hose (pump drain)	1	
6	Hydraulic hose (pump return)	1	
7	Hydraulic hose (boom cylinder - control valve)	4	
8	Hydraulic hose (arm cylinder - control valve)	2	
9	Hydraulic hose (bucket cylinder - control valve)	4	
10	Hydraulic hose (swing motor - control valve)	2	
11	seat belt	1	Every 2 years

Maintenance schedule

If the machine is equipped with hydraulic hammer, the maintenance schedule of some parts is different. For details, see "Maintenance Cycle when Using hydraulic hammer" to determine the correct maintenance schedule when performing maintenance.

Maintenance schedule

Maintenance schedule and procedures refer to the maintenance Table, which is pasted on the vehicle.

Check before operation

For details of the following items, see "Pre-job inspection" in the operations section.

- Cooling system coolant level - check/fill
- Engine oil level - check/fill
- Fuel oil level - check/fill
- Air filter dust indicator - check
- Hydraulic oil level - check/fill
- Electrical wiring - Inspection
- Horn function - check

Irregular maintenance

- Air filter element - inspection/cleaning
- Internal cleaning of cooling system - cleaning/replacement
- Water and sediment in the fuel prefilter - discharge
- Water and sediment in fuel tank - discharge
- Track tension - check/adjust (machine with metal track board, road liner)
- Bucket teeth - replacement

First 50 hours of maintenance (first 50 hours only)

- Engine oil and oil filter element - replacement

The first 500 hours of maintenance (only in the first 500 hours, and also every 250 hours of maintenance)

- Fuel fine filter element - replacement
- Gear oil for walking reducer - replacement

The first 1000 hours of maintenance (only in the first 1000 hours, at the same time every 500 hours of maintenance)

- Hydraulic oil return filter element - replacement
- Air filter main filter element and safety filter element - replacement

Every 8 hours maintenance

For details on the following items, see the Operation/Maintenance section.

- Working device grease – fill

- Coolant level in cooling system - check/fill
- Engine oil level - check/fill
- Fuel level - check/fill
- Hydraulic oil level - check/fill
- Fuel pre-filter - check/drain
- Electric wiring - check
- Alternator belt tension – check/adjust

Every 100 hours of maintenance

- Engine oil and oil filter -- check/fill

Maintenance every 250 hours

- Engine oil and oil filter element - replacement
- Grease for slewing bearings and pinion gear - fill
- Radiator and condenser fins - check/clean
- Gear oil level of walking reducer - check
- Fan belt - check/adjust
- Lock core - maintenance/lubrication
- Hinge - maintenance/lubrication

Maintenance every 500 hours

- Fuel fine filter element - replacement
- The guide cartridge - replacement
- Gear oil for walking gear reducer - replacement
- Fuel pre-filter element - replacement
- Maintenance every 250 hours shall be performed simultaneously

Maintenance per 1000 hours

- Hydraulic oil return filter element - replacement
- Gear oil for walking reducer - replacement
- The guide cartridge - replacement
- Air filter main filter element and safety filter element - replacement
- Grease for slewing support gear - inspection
- Maintenance should be performed at the same time every 250 and 500 hours

Every 2000 hours of maintenance

- Hydraulic oil - change
- Suction filter element of hydraulic oil tank – change
- Preloaded air filter (hydraulic oil tank breathing valve) - change
- Maintenance should be performed at the same time every 250, 500 and 1000 hours

Maintenance every 3,000 hours

- Grease in oil pool of rotary device – replacement

- Coolant - replacement (recommended)
- Maintenance should be performed at the same time every 250, 500 and 1000 hours

Notice: Special tools are required for inspection and maintenance. Please contact CFG dealer.

Maintenance Interval for Hydraulic Breaker

For machine equipped with a hydraulic breaker, the hydraulic oil deteriorates faster than for normal bucket digging operations, so set the maintenance intervals as follows.

- Replace hydraulic filter element

On a new machine, replace the element after the first 100 to 150 hours, then carry out further replacement of the element according to the table on the right.

- Change oil in hydraulic tank

Change the oil according to the table on the right.

X: Breaker operating ratio (%)

Y: Replacement interval (H)

(A): Hydraulic oil return filter, hydraulic tank breathing valve filter, pilot filter replacement cycle

(B): Hydraulic oil replacement cycle

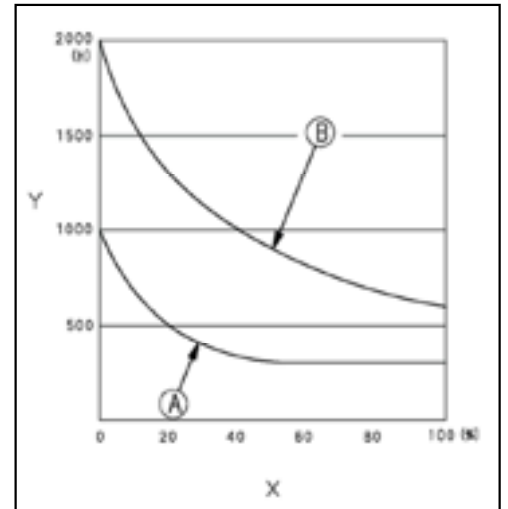

REMARK:

- Breaker operating ratio 100% means that only the breaker is used
- Breaker operating ratio 0% means that the breaker is not used
- The hydraulic mailbox breathing valve filter element needs to be cleaned irregularly in the replacement cycle.

Maintenance procedures

Engine maintenance and maintenance

Engine oil and oil filter element - replacement



If the engine is operated without sufficient heating, the working device will become slow in response to the joystick and cannot move as intended by the operator. Therefore, after the engine is started, idle for 5 minutes to warm up the engine. Especially in cold areas, be sure to carry out adequate heating operation.

Sudden engine shutdown will greatly shorten the service life of the engine components. So do not suddenly shut down the engine except in emergencies. The engine should be run at a low idle speed for about 5 minutes to cool the engine gradually.

After the engine stops, parts and oil are still in a high temperature state, which can easily lead to burns. We can't start working until the temperature cools down.

Waste oil and liquid should be disposed of in an environmentally friendly manner

NOTE

When using CI-4, change the oil every 250 hours or 3 months (50 hours for the first time), whichever comes first. The conditions applicable to the 250-hour interval are:

The oil filter meets the engine specification, as do the original components.

Sulphur content of engine fuel shall not exceed 0.1% by weight.

The oil used meets the requirements

The oil used conforms to "recommended lubricants and accessories".

Select the correct oil viscosity relative to the ambient temperature, see "Correct selection".

Change the oil and oil filter every 100 hours if any of these conditions are not present, or if the machine is operating in an acidic, particularly dusty environment, or using fuel with sulphur content greater than 0.5%.

NOTE

- Pan replacement oil volume: 3.4L
- Prepare a strainer wrench.
- During inspection, if the machine is tilted, it should be in a level state before inspection.
- Need to check the oil level every day, too much or too little oil will cause trouble.

1. Place an oil container directly under the plug (P) at the bottom of the machine. Loosen the plug with 18mm extension sleeve (P).

2. In order not to let the oil splash on the body, do not remove the plug first, let the oil slowly discharge from the plug (P). At the end of discharge, remove the plug completely to drain all oil from the sump.

3. Check the oil discharge. If you find a lot of metal shavings and foreign matter, please contact the dealer.

4. Install plug (P).

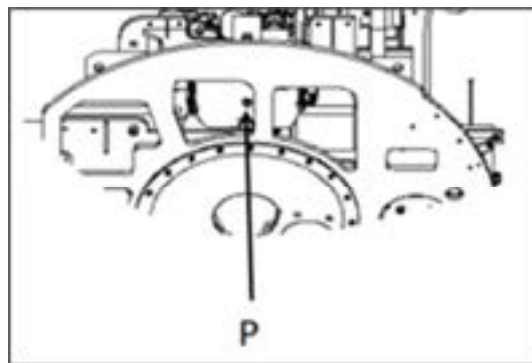

Fan belt - check/adjust

The engine must be stopped while checking the fan belt tension, as rotating parts can cause personal injury.

NOTE

Check the fan belt every 250 hours.

CHECK

With about 98N (10kGF) force, press the middle part of the crankshaft pulley and fan pulley, if the deflection is 7 ~ 9mm, it is qualified.

ADJUST

□ lever

□ Prepare wooden blocks.

1. Open the rear hood of the engine and lock it with the brace.
2. Loosen the adjusting bolts and mounting bolts of the ALTERNATOR.
3. Adjust the alternator, press the middle part of the crankshaft pulley and fan pulley with a force of about 98N, so that the deflection is 7 ~ 9mm.
4. Tighten the adjusting bolts and mounting bolts of the ALTERNATOR.
5. Check whether the pulley is damaged, whether the V-groove is worn and whether the V-belt is worn. In particular, check whether the v-belt is in contact with the bottom of the V-groove.
6. If the belt has been stretched without adjustment margin or there is a cut or crack on the belt, please contact the local dealer for replacement in time.
7. After adjusting the rear cover, put on the rear engine cover and lock it.

□ The surrounding of the hydraulic tank breathing valve needs to be cleaned irregularly during



Fuel system maintenance and maintenance

Water and sediment in fuel tank - discharge

NOTE

- Only diesel oil should be used when flushing the inside of the tank.
- For routine maintenance, water and sediment in the fuel tank can be discharged from the bottom of the fuel tank plug.

Fuel pre-filter element - replacement/maintenance

(1) Fuel pre-filter - drainage and cleaning



- After engine shutdown, all parts are still in a high temperature state, so do not replace the filter immediately. The replacement can only be carried out after the temperature of each part comes down.
- When the engine is running, there is high pressure in the fuel hose. After the engine is stopped, wait for 30 seconds to release the pressure before operation.
- Do not go near an open flame.
- Prepare a strainer wrench.
- Prepare a container for discharging fuel.
- 1. Open the engine cover, ensure that the brace is locked, and place the valve in the closed position.
- 2. Remove the water collecting cup of fuel pre-filter and drain the water clean. If the water collecting cup contains impurities, clean the water collecting cup with clean diesel oil.
- 3. After cleaning the water collecting cup, install the water collecting cup by rotating the filter wrench counterclockwise.
- 4. Open the valve, loosen the brace and close the engine cover.

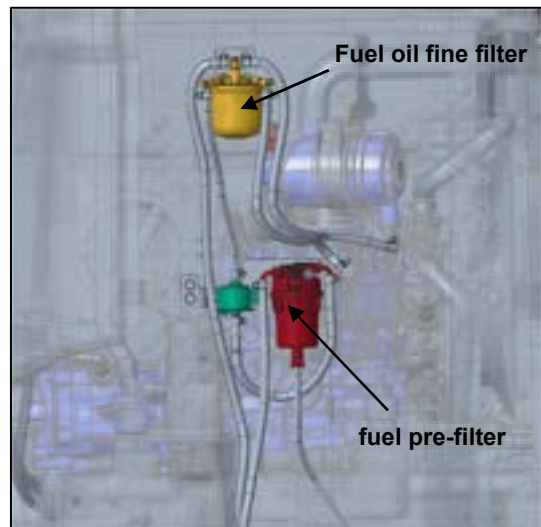

NOTE

- The water in the water cup needs to be drained frequently, and if it is mixed with the fuel, it will cause damage to the engine.
- When impurities accumulate in the cup, clean the cup immediately, otherwise impurities may enter the engine and cause engine clogging or early wear.

(2) Fuel oil fine filter element - replacement

- 1. Open the rear hood of the engine and lock the rear hood with a brace.
- 2. Turn the fuel fine filter element to the left with the filter element wrench, and remove the filter element.
- 3. Clean the filter seat, coat the sealing ring of the new filter element with oil, turn the filter element to the right by hand, until the sealing gasket of the filter element contacts the sealing surface of the mounting seat.
- 4. Tighten the filter 3/4 to the right with the filter wrench.

- 5. After the replacement of the fine filter element, open the valve for exhaust. See "Fuel system exhaust" for exhaust method.

Pay attention to

- It is not allowed to fill the fuel directly into the filter element of the fine filter, otherwise the fuel that does not pass the fine filter will cause nozzle blockage or system failure.
- The filter element must use pure parts of mountain reconstruction machine, otherwise it will lead to foreign body entry or oil injection system failure.

Fuel system - exhaust

! WARNING

- When working with fuel injection equipment, ensure that high-pressure fuel does not come into contact with unprotected parts of your body.
- If the tank runs out of oil or air enters the fuel system for some reason, air must be expelled from the fuel system.

In any case, ensure that the fuel system is completely sealed before starting the engine, otherwise the fuel injection pump can be seriously damaged as a result.

1. Switch the start key to the ON position to power up the electronic fuel pump and start working.
2. Keep the power on for at least 10 minutes to ensure that the oil circuit is full of fuel oil.
3. Start engine and run engine at low idle for approximately 10 minutes with safety locking lever in lock position.
4. Check to confirm no leakage after startup.

NOTE

- The exhaust method is the same when the fuel is exhausted.

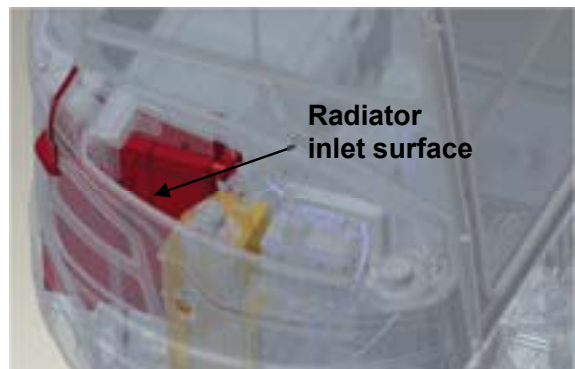

Maintenance of cooling system

Radiator and condenser fins - clean

! WARNING

- Compressed air, steam or water may cause personal injury. Wear protective equipment such as protective eye mask. Radiator fins are easy to fall down.
- When using compressed air, keep a proper distance from the radiator fins to prevent damage.
- Blow on the radiator core vertically. If the radiator is damaged, it will cause leakage or overheating.
- Daily inspections are carried out on dusty work sites without limitation of maintenance intervals.

1. Open the right hood, lock it with a brace;
2. Use compressed air to remove all sludge, dust and leaves attached to the fins of the water radiator and hydraulic oil radiator (radiator inlet surface), and clean the air filter at the same time.
3. Close the right hood and lock it.

NOTE

- All fins must be cleaned every 250 hours.
- The air filter on the side door should be cleaned as long as there is debris or too much dust.

Internal cooling system - cleaning/replacement**NOTE**

- The coolant is antifreeze and antirust. Check the antifreeze performance of the coolant every 500 hours.
- It is recommended to replace the coolant every 2 years or 3000 hours, in advance according to the use of coolant.
- If the coolant is not replaced in time, the cooling system may be blocked and the engine may be stuck to the cylinder.
- The cooling system needs to be cleaned each time the coolant is changed.
- Do not inject cold coolant into an engine that is running or has just finished but the body temperature is still very high. This may cause cracks in the cylinder block and head.
- Cooling system capacity is approximately 5 litres when filling.
- When the plant starts, the cooling system has been filled with a mixture of coolant, water and concentrated antifreeze, which can lower the freezing point of the coolant and increase its boiling point.
- The concentrated coolant contains an effective anti-rust additive to protect the engine and radiator internal waterways, but the additive is of limited duration.
- Do not mix the special coolant for mountain reconstructors with any antifreeze or additives made by other manufacturers. The mixture may have negative effects.
- The content of antifreeze should not be less than 40% in the coolant. The proportion of antifreeze to 40% of the coolant can reduce the freezing point to -25°C . Antifreeze is 50% of the coolant, which can lower the freezing point to -37°C .
- When determining the coolant (antifreeze) to water mixing ratio, check the past minimum temperature. In practice, when determining the mixing ratio, set it at a temperature 10°C below the minimum temperature.
- the replacement cycle.

Air filter maintenance and maintenance

Overview of air filters

The air filter prevents dust and other impurities from entering the engine. The air first passes through the main filter element of the outer filter, and then through the safety filter element. Engine wear depends largely on the cleanliness of the intake air.

Therefore, it is very important to check the air filter regularly and maintain it.

Air filter adopts radial seal and double filter form. Air filter structure is as follows:

- A. Differential pressure indicator (optional)
- B. joint
- C. Air filter housing
- D. Safety filter element
- E. the primary filter
- F. Air filter end cover
- G. dust exhausting valve
- H. Check The Times label
- I. lock

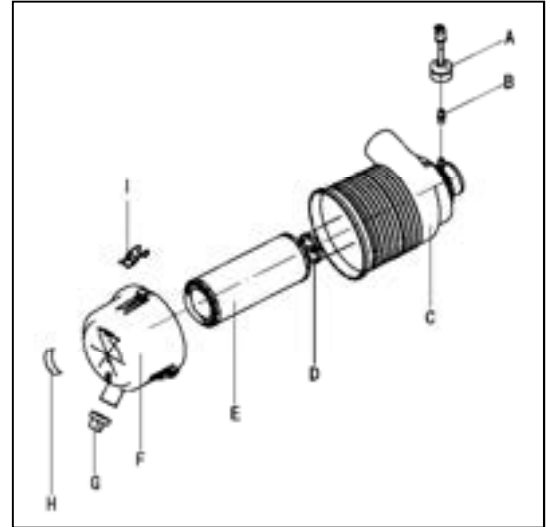

NOTICE

- Under no circumstances should you run an engine without an air filter or if the air filter is damaged.
- Check the pipeline from the air filter to the engine intake manifold periodically for leaks and damage.
- Prepare a spare air filter and store it in a dry and dust-proof place.
- If the engine is inspected, cleaned or replaced while it is running, dust will enter the engine and cause engine damage. Before performing these operations, shut off the engine.
- There is a danger of dirt flying out and causing injury when compressed air is used. Wear protective glasses, dust mask or other protective devices.

Air filter. - Check

Open the engine rear hood to check whether the air filter alarm displays alarm

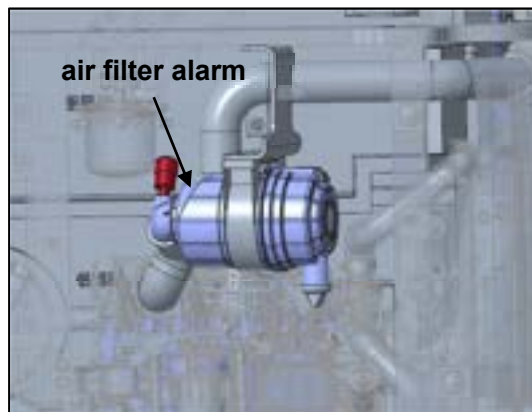

IMPORTANT

- If the air filter element is frequently cleaned before the alarm, the performance of the air filter can not be fully played, making its filtering effect worse.
- In addition, dirt attached to the filter element during cleaning will frequently fall to the inner filter side, suction engine, resulting in engine wear.

Air cleaner - Clean up

1. Open the engine cover and ensure that the brace is locked.
2. Open the three locks on the end cover of the air filter (I).
3. Remove the end cover of the air filter (F).
4. Empty and clean the end cover and dust exhaust valve (G), and clean the inside of the end cover shell with a clean cloth.
5. Remove the main filter element (E).

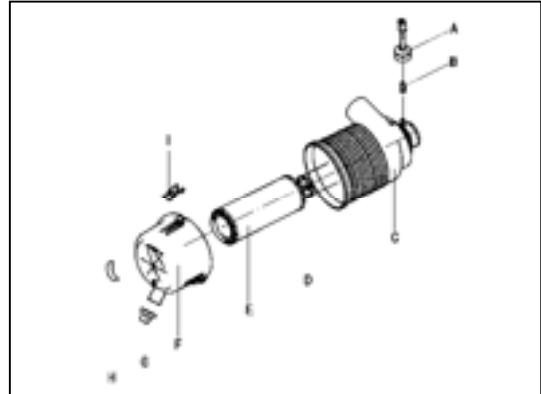
NOTICE

- If the dust valve (G) is cracked, damaged or lost, the dust valve needs to be replaced. If the dust valve is intact, the dust valve needs to be cleaned.
 - Main filter element (E) adopts radial seal, there will be a certain resistance when taking off, should be pulled out while rotating the main filter element, remember not to beat the shell and the main filter element.
 - Do not remove the safety filter element (D), otherwise, dirt is easy to enter and cause engine failure. Unless the safety filter element is damaged and spare parts are ready for replacement.
6. Check and clean the main filter element (E) and shell (C).



- Mechanical cleaning: the main filter element on a soft, clean object surface carefully beat the end of the filter element, do not rely on a hard object violently hit or
- hit the filter element.
- Compressed air cleaning: dry compressed air (less than 0.69mpa {7kg/cm²}) from the inside of the filter along the fold to blow outward, and then from the outside of the filter along the fold to blow inward, and again from the inside to blow outward, nozzle and filter surface distance is not less than 3 ~ 5cm.
- The outer filter element needs to be replaced after 6 times of cleaning or after 1000h. The safety filter element should be replaced when the external filter element is replaced.
- Even if the cleaning times of the outer filter element did not reach 6 times, the alarm still alarms when the filter element is blocked after cleaning, and the inner filter element and the safety filter element need to be replaced.

7. After cleaning the filter element, use light to illuminate the inside of the filter element or reverse sunlight to check. If there are holes or thin parts on the filter element, replace them.

NOTICE

- Must not be knocked to clean the main filter element;
- The life of the filter element cannot be judged only by eye observation, the pressure differential indicator is the most reliable;
- Air filter end cover (F) cannot be opened for too long, if there is no suitable filter element to replace immediately, should immediately cover the end cover;
- Pure air filter element for mountain reconstruction machine must be used.

8. Push the edge of the main filter element (E) by hand, carefully install the main filter element, and confirm that the main filter element is fully loaded into the shell.

9. Make the TOP arrow of the end cover (F) face up and install it on the shell of the air filter, and fix it with the lock (I).

Pay attention to

- Cannot use the force of the end cover to push the main filter element, which will damage the housing and the lock.
- If the end cover cannot be installed in place because of the main filter element, remove the end cover and continue to push the main filter element until the main filter element is installed in place.
- The dust valve on the end cover should be kept facing down for dust removal.

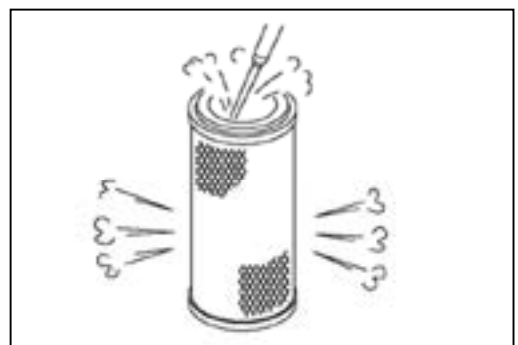

- For each cleaning of the main filter, one label on the check times label (H) at the end cover of the empty filter should be torn off. The label can be cleaned up to 6 times, and then it must be replaced.

Air filter element - replacement

1. Open the engine cover and ensure that the brace is locked.
2. Open the lock on the end cover of the air filter (I).
3. Remove the end cover of the air filter (F).
4. Empty and clean the end cover and dust exhaust valve (G), and clean the inside of the end cover shell (F) with a clean cloth.
5. Remove the main filter element (E).

Pay attention to

- Do not remove the safety filter element at this time
 - If the dust valve (G) is cracked, damaged or lost, the dust valve needs to be replaced. If the dust valve is intact, the dust valve needs to be cleaned.
 - Main filter element (E) adopts radial seal, there will be a certain resistance when taking off, should be pulled out while rotating the main filter element, remember not to beat the shell and the main filter element.
6. Clean the inside of the air filter shell (C) with a clean cloth.
 7. Prepare the new main filter element and safety filter element, and check whether the new filter element is damaged, if there is damage, replace it immediately.
 8. Remove the safety filter element (D) and quickly install the new safety filter element.
 9. Push the edge of the main filter element (E) by hand, carefully install the main filter element, and confirm that the main filter element is fully loaded into the shell.
 10. Make the TOP arrow of the end cover (F) face up and install it on the shell of the air filter, and fix it with the lock (I).

NOTE

Safety filter filter efficiency is generally much lower than the main filter, the filter area is much smaller, maintenance work, can prevent impurities into the engine.

When the main filter is damaged, the safety filter will protect the engine.

If the main filter element has been cleaned or replaced, but the differential pressure indicator alarm, it indicates that the safety filter element is blocked.

NOTICE

Safety filter element can only be replaced, not cleaned.

Safety filter element is generally replaced at the same time when the main filter element is replaced.

Do not remove the safety filter element unless it needs to be replaced.

Remove the safety filter element should be very careful, and the removal action should be accurate in place, so that impurities are not easy to enter the engine.

After replacing the safety filter element, carefully check to ensure that the new safety filter element is installed correctly.

Operation instructions for electric welding

- The battery switch must be turned off before welding the machine or any device installed on the machine.
- Disconnect the battery cable and unplug the cable plug from the electronic controls before any welding is performed on the machine.
- Turn off the battery switch when disconnecting and reconnecting.
- The grounding wire of welding equipment should be as close to the welding point as possible.
- Remove all paint within a radius of at least 10 cm (4 inches) around the weld before welding. Because heated paint gives off harmful gases.

All paints break down when heated and form large amounts of compounds that can cause pain, irritation and health hazards if exposed to them for long periods of time.

- In addition to health hazards, welding quality and strength will be damaged, and even lead to future weld fracture. Therefore, do not directly on the paint surface welding.

Maintenance of Hydraulic System

Hydraulic Oil Return Oil Filter Element - Replacement



- After the engine is stopped, the parts are still in the high temperature state, so do not immediately replace the oil filter element. The parts cannot be replaced until the temperature drops.

Notice

- If the machine is equipped with a hydraulic crushing hammer, the hydraulic oil will deteriorate faster than normal bucket work. See the item "maintenance cycle when using hydraulic crushing hammer" for the replacement cycle.
 - The filter element of the return oil filter should be replaced every 1000 hours after the first use and every 1,000 hours after that.
1. Remove six fastening bolts (S=13) from flange assembly (1).
 2. Remove flange assembly (1).
 3. Unscrew the return oil filter element (2), then replace the new return oil filter element.
 4. Except for filter element (2), clean the removed parts with clean diesel oil.
 5. Install flange assembly (1) as is and tighten with bolts.

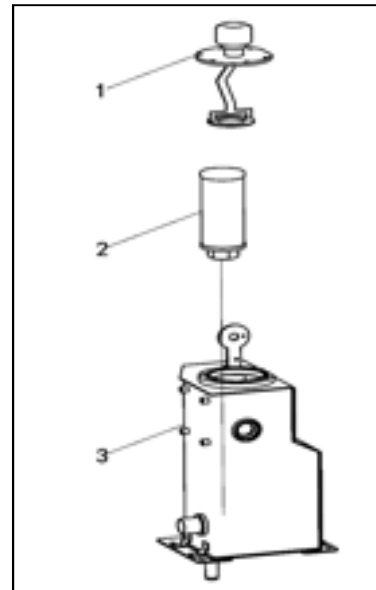

Hydraulic tank oil filter element - check/clean/replace



- After the engine is stopped, all parts are still in the high temperature state, so do not immediately clean the oil absorption filter. The parts cannot be replaced until the temperature drops.
- Oil may spout when the cap of the suction port is removed. Press the top button of the breather valve to release pressure inside the tank before removing the cap.

Notice

Check and clean the oil filter element of the hydraulic oil tank after the first use of 50 hours and 500 hours, and then check and clean it every 500 hours. Replace every 2000 hours. This maintenance time is halved when using the crushing hammer.

1. Remove six fastening bolts (S=13) from flange assembly (1).
2. Remove flange assembly (1).
3. Unscrew the oil filter element (3) from the oil tank (2).
4. Check whether there are metal particles and other impurities on the oil filter element. If there are, please contact the dealer immediately for diagnosis and maintenance. If not, clean the removed filter element and other parts with clean diesel.
5. Load the cleaned oil filter element or the new oil filter element into the filter seat in the oil tank.
6. Install flange assembly (1) as is and tighten with bolts.

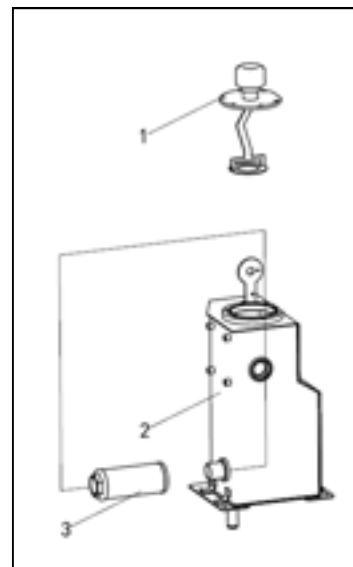

Hydraulic Oil Replace



- After the engine is stopped, all parts and hydraulic oil are still at high temperature, so do not immediately replace the hydraulic oil and filter element, or it will cause burns. To wait for the parts and hydraulic oil temperature down after the start of maintenance..
- Oil may spout when the cap of the suction port is removed. Press the top button of the breather valve to release pressure inside the tank before removing the cap.

- Oil receptacles shall have a capacity of at least 32L.
- Fuel capacity: about 32L.
- Prepare 10mm square.
- Prepare new preloaded air filter 1 piece.

1. Rotary machine makes the oil discharge screw plug under the hydraulic oil tank located in the middle of the left and right tracks.

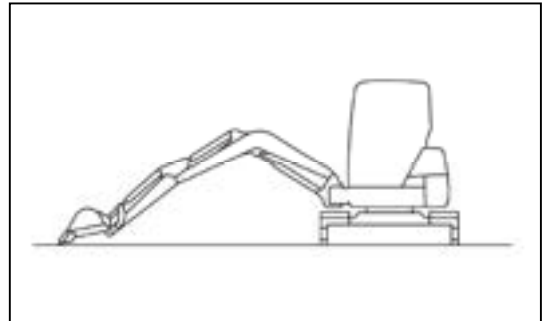

2. Retrieve the oil cylinder of the bucket rod and bucket, lower the moving arm and dig the bucket tooth into the ground. And lower the bulldozer to the ground.

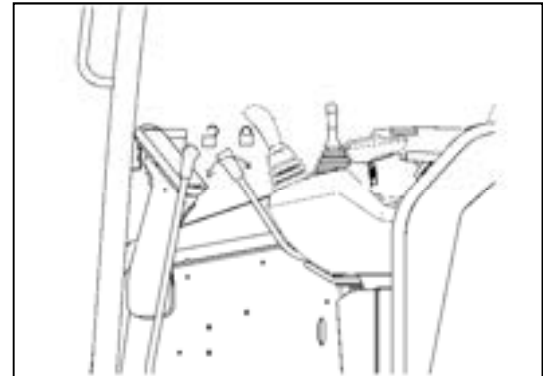

3. After flame out, turn the electric lock to the ON position and put the safety lock lever in the position E . Shake the control handle left and right to release the pressure inside the system. After completion, turn the electric lock to the OFF position and put the safety lock lever in the locked position D .

4. Place the oil receiving container under the drain screw plug (4) under the oil tank. Remove the lower drain screw (4) to drain oil .and loosen the upper fill screw plug (1).
5. Remove the upper flange cover after bucket, charging the oil. Clean the top flange cover and the bottom of the tank remaining impurities and other contaminants.
6. At this time, it is necessary to carry out maintenance at the same time to clean or replace the oil absorption filter element and oil return filter element. The replacement method is described in the previous three pages.
7. Install the upper production cap and drain screw plug (4) and screw it. Check the D shape diagram installed on the cap and screw plug. If damaged, please replace the O shape diagram.
8. After the replacement, add hydraulic oil to the specified amount of replacement oil through the filling screw plug to check whether the oil level is in the middle of the middle of oil level gauge.
9. Install the new preloaded air filter (1) and tighten it.
10. After the replacement of hydraulic oil, put each connecting rod in the middle position make the engine idle for 2-3minutes, exhaust each action, replenish the hydraulic oil to the middle position of the oil level meter and then start the operation.

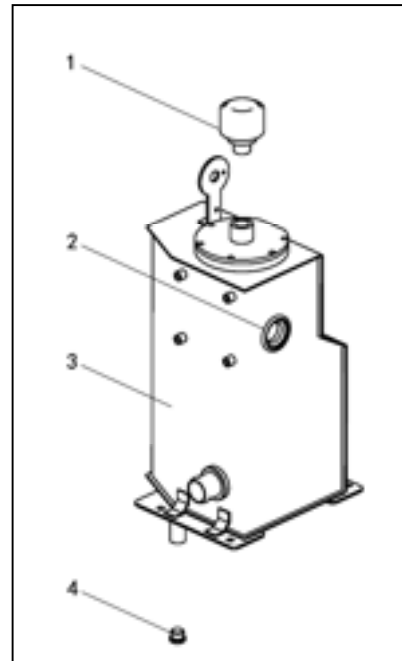

Gear Oil in Running Motors and Reducers - Inspection/Refueling

WARNING

- When the engine stops, the parts and gear oil are still in a high temperature state, which is easy to cause burns. Wait for the temperature to cool before starting the operation. .
- If pressure remains in the gearbox, oil or studs may fly out. Slowly loosen the plug to release internal pressure.

- Prepare socket wrench.
- Replace the gear oil in the walking reducer after 500 hours of first use, and replace the gear oil in the walking reducer after 250 hours of first use. During normal operation, check and add gear oil every 250 hours, and replace gear oil in the walking reducer every 1000 hours.

1. Position the motor in the shown position
2. Use an inner hexagon wrench to remove the stud plug of the oil opening and check whether the internal gear oil is under the gear oil opening and check whether the internal gear oil surface of the oil opening through the stud plug hole
3. If the oil level is too low, it is necessary to fill the same specification of gear oil from the oil filling port.
4. when filling the gear oil flows out of the oil filling hole, tighten the screw plug and clean the oil pollution at the reducer shell with a clean cloth

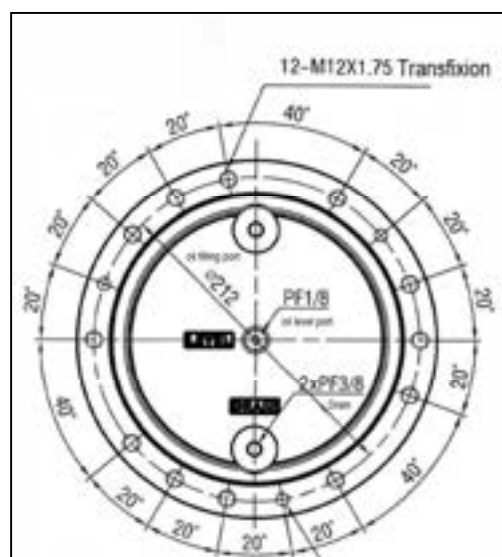

Hydraulic System - Exhaust

Notice

If the pump housing is not filled with hydraulic oil when the pump operation, will cause abnormal high temperature pump, pump may be prematurely damaged. Therefore, exhaust must be carried out.

1. Discharge air from the main pump

- 1) Open the rear cover and remove the hose and connector at (1) of the main pump.
- 2) Slowly fill the oil port with clean hydraulic oil. When it is seen that the liquid level of the oil port is almost full and there are large bubbles, the filling is suspended.
- 3) After the liquid level at the oil port stops bubbling, the liquid level will decline. At this time, slow refueling is conducted again until the liquid level is almost full and stable and no longer drops.

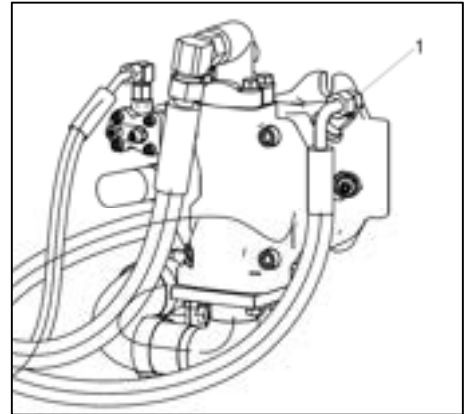

- 4) Check whether the seal ring of the joint hose is damaged, and replace the seal ring if it is damaged. Tighten the adapter hose. Clean up any spilled oil.

2. Refer to "starting engine" in the operation section, starting engine. Start the engine at a low idle speed for 10 minutes before proceeding to the next operation.

3. Drain the air in the oil cylinder

Notice

If the engine is initially run at high speed and the cylinder is operated to the end of the stroke, damage to the plunger seal will result from air entering the cylinder.

- 1) Run the engine at low idle speed, and extend and withdraw each cylinder for 4 to 5 times. Be careful not to operate the cylinder to the end of the stroke (stop at 100mm from the end of the stroke).
- 2) Then, operate each cylinder to the end of its stroke for 3-4 times.
- 3) Finally, operate each cylinder to the end of its stroke 4-5 times to completely exhaust air.

4. Exhaust air from accessories (when equipped with accessories)

If a crusher or other accessory is installed, run the engine at a low idle speed and repeatedly operate the accessory pedal (about 10 times) until air is expelled from the accessory oil path.

Notice

- If the manufacturer has specified the method of exhaust from the annex, exhaust in accordance with the specified method.
- After the exhaust operation is completed, shut down the engine and wait 5 minutes before starting again to eliminate the oil bubbles in the hydraulic cylinder.
- Check for leaks and wipe up any spilled oil.

5. After the above exhaust is completed, check the oil level of the oil gauge of the hydraulic oil tank. If it is insufficient, add the hydraulic oil to the specified oil level.

Crawler tension- inspect/adjustment Machine with metal treads

Wear of the pins and bushings of the lower body varies with operating conditions and soil types. Therefore, in order to maintain the standard tension, to each 250 hours. Check the tension of the track for hours.

For inspection and maintenance, park the machine in a firm, flat place.

CHECK

1. Run the engine at low idle speed and slowly move the machine forward for a distance equivalent to the length of contact between the track and the ground, then stop the machine.
2. Check whether the track board is broken or damaged.

Track Tension-Adjustment

WARNING
 Be sure to loosen the plug. 1 More than one lap.
 If the screw plug 1 Loosened more than a circle, under the high pressure of grease, there is a risk of flying out. At this point, do not loosen the screw removal plug 1 Do not face the plug for any part other than the plug 1 The installation direction of the.
 If the method provided here does not loosen the track tension, contact the dealer and commission the repair.

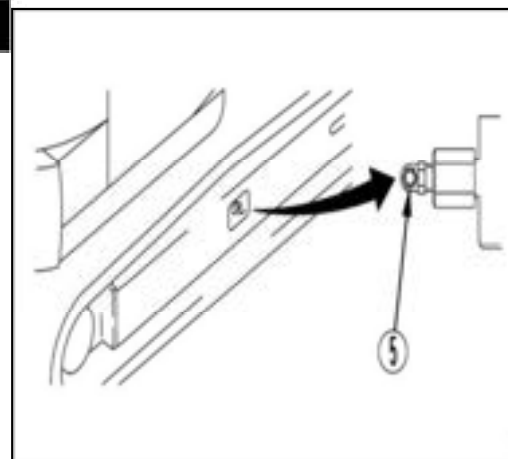

Replace Bucket Teeth

Replace the teeth before the wear reaches the adapter.

WARNING
 It is dangerous if the work equipment is mistakenly moved when replacing the teeth. Set the work equipment in a stable condition, stop the engine, then set lock lever securely to the LOCK position.

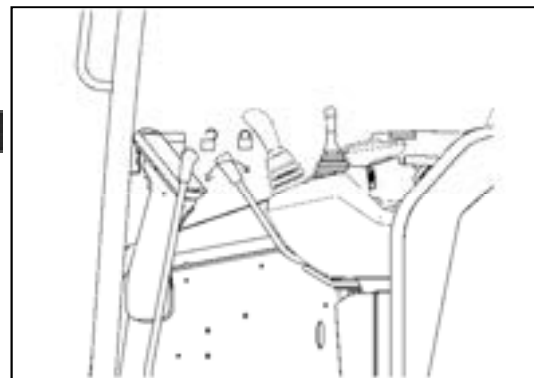

Working Device Grease - filling

Notice

The grease filling point of the working device lubricates every 8 hours (every day).

If there is abnormal noise in the parts that need lubrication, the lubrication should be carried out regardless of whether there is time for maintenance.

When excavating in water (on civil land, etc.), lubricate the pin shaft immersed in water.

1. Lubricate according to the lubrication position in the right picture. Lower the actuator to the ground and shut off the engine.

2. Grease pump is used to inject grease through the grease nozzle shown by the arrow.
3. After lubrication, wipe off the old squeezed grease
 - (1) Bucket and connecting rod connecting pin (1 place)
 - (2) Bucket bar and bucket connecting pin (1 place)
 - (3) Bucket bar and rocker arm connecting pin (1 place)
 - (4) Both end of bucket cylinder (2 place)
 - (5) Bulldozing shovel shovel cylinder at both ends (2 place)
 - (6) Push shovel root pin (2 place)
 - (7) Both ends of boom cylinder (2 places)
 - (8) Both ends of cylinder bucket rod (2 place)
 - (9) Bucket rod cylinder piston rod end (1 place)
 - (10) Boom root pin (1 place)
 - (11) The swing frame is connected with the platform shaft (2 place)
- Yaw both ends of cylinder (2 place)

Maintenance and Lubrication of Lock Core

WARNING

- After the door lock is used for a period of time, there will be dust and impurities in the lock core, which will cause the lock core to become stuck and fail to open. Do not force it to open, otherwise the lock core will be damaged.
 - Fill the lubricant every 250 hours.
-

When the key is inserted halfway, the lock core dust cover is opened. At this time, the carburetor cleaning agent is sprayed into the lock cylinder. The key is fully inserted into the lock cylinder for several rotations, half of the key is pulled out, and the cleaning agent is sprayed again. It can effectively remove internal impurities.

After cleaning, add a small amount of diluted lubricant.

In addition, pre-tighten the hood lock shaft and apply a small amount of lubricant to the lock shaft and lock contact.

Maintenance and Lubrication of Hinge

WARNING

- After the hinge is used for a period of time, dust, impurities, etc. may cause the hinge to be stuck and the door/cover to be closed. Do not forcibly open the door/cover at this time, otherwise the door/cover will be damaged.
 - Add lubricant once every 250 hours.
-

Clean dust and impurities from the door/cover and apply a little lubricant to the hinge.

Slewing and Pinion Grease - Check/Refill



Do not turn the slewing bearings and slewing pinions while lubricating them.

Filling of Grease

Lubricate the slewing bearing and pinion grease every 250 hours. Do not lubricate frequently.

1. Lubricate through the yellow nozzle shown by the arrow (right side of the car).

(1) slewing support (1 place)

(2) rotary gear (1 place)

2. After lubrication, wipe off the old squeezed grease.

When lubricating the slewing bearings and slewing gears, the machine may be rotated slightly to change its position.

便签页

SPECIFICATION

**WARNING**

Please read and make sure that you understand the SAFETY section before reading this section.

Specifications

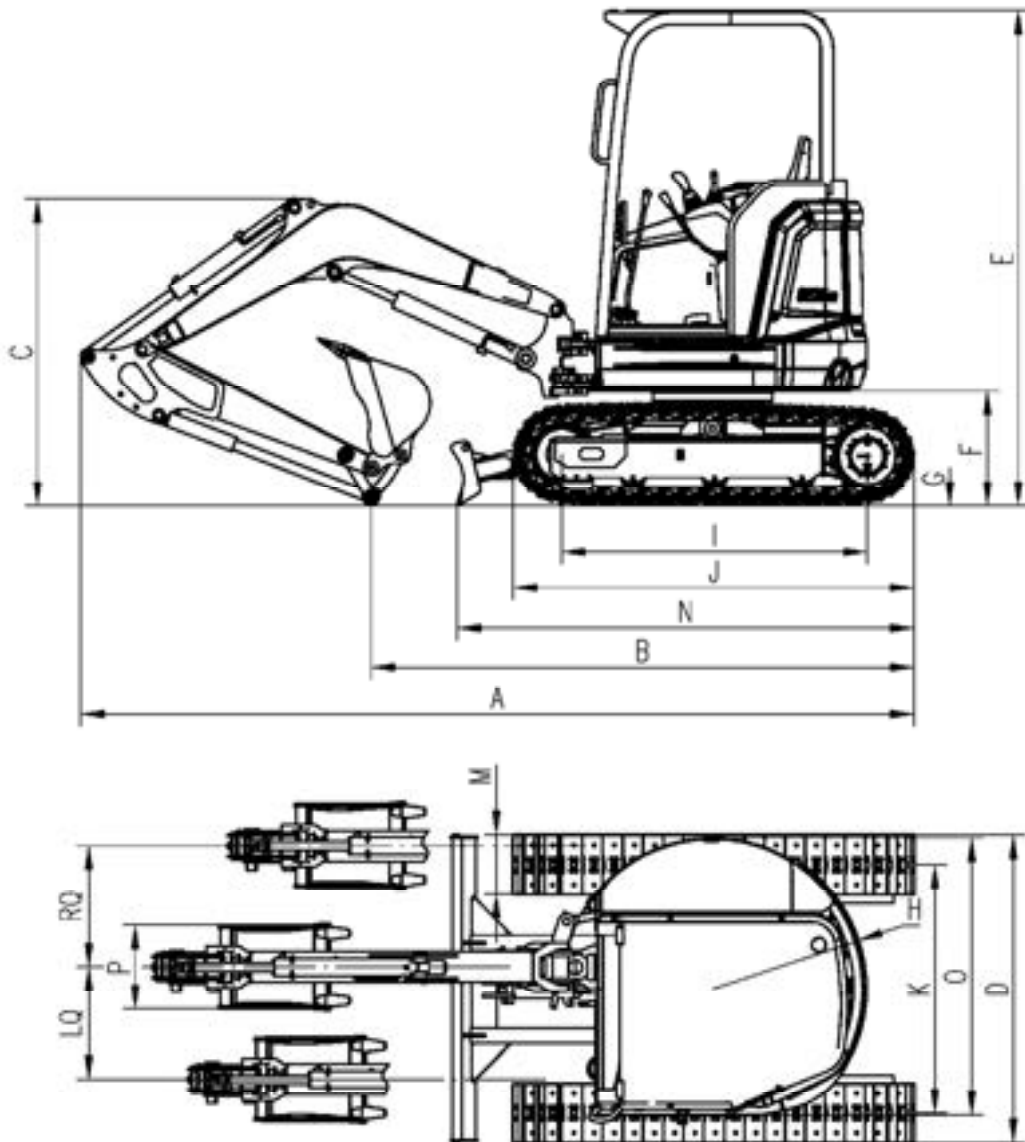

Specifications

	Item	Unit	Parameter
A	Overall length	mm	4200
B	Grounding length (Transportation)	mm	2740
C	Overall height(to the top of boom)	mm	1545
D	Overall width	mm	1550
E	Overall height(to the top of cab)	mm	2480
F	Counterweight ground clearance	mm	575
G	Min. Ground clearance	mm	270
H	Tail radius of turning	mm	775
I	Tumbler center distance	mm	1540
J	Length of track	mm	2020
K	Gauge	mm	1250
L	Track width	mm	1550
M	Track shoe width	mm	300
N	Turntable width	mm	2300
O	Item	mm	1400
P	Turntable width	mm	490
RQ	Right arm offset	mm	610
LQ	Left arm offset	mm	565
RT	Right offset angle of boom	mm	55°
LT	Left offset angle of boom	mm	65°

Working Ranges

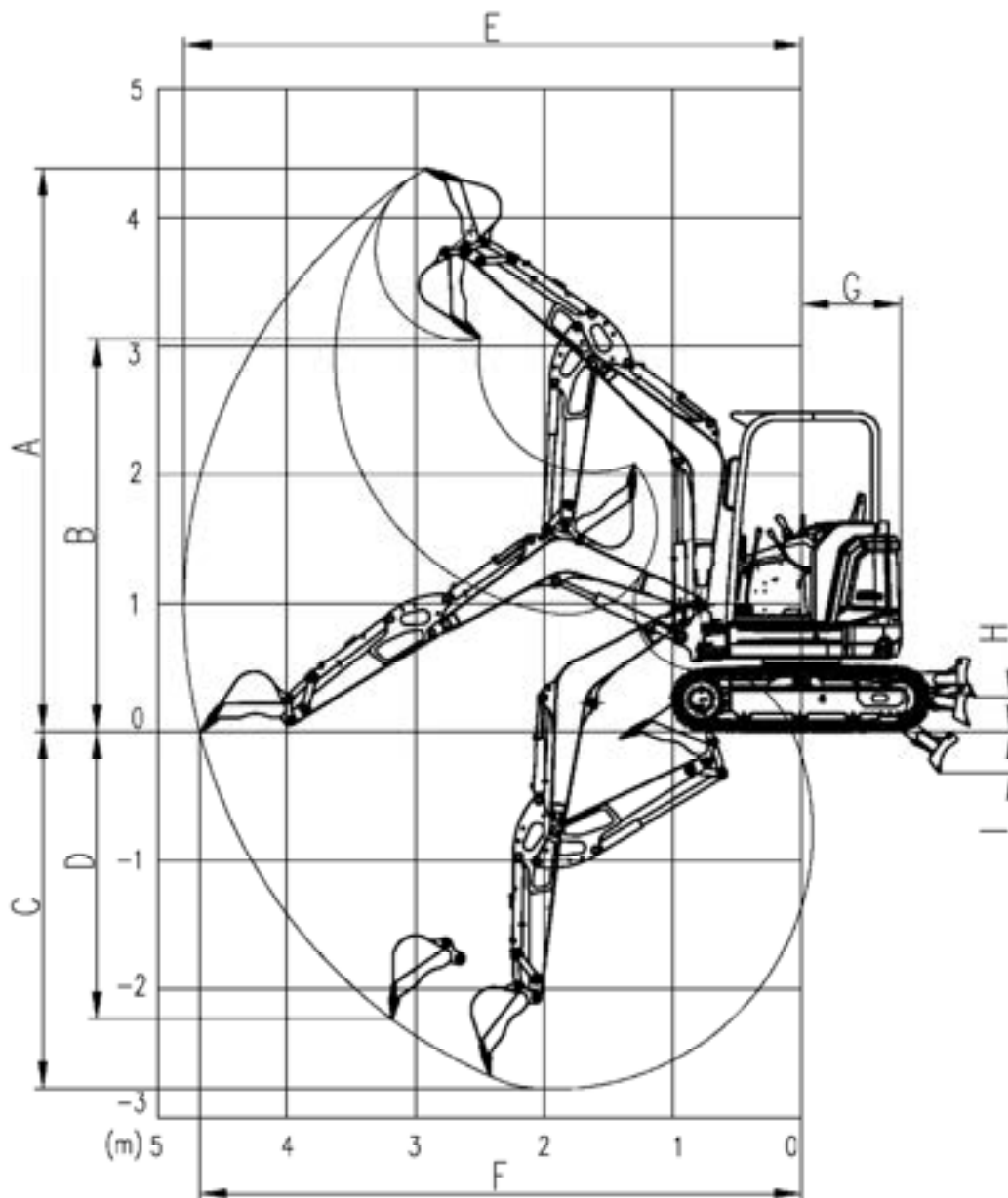

	Item	Unit	Parameter
A	Max. Digging height	mm	4390
B	Max. Dumping height	mm	3060
C	Max. Digging depth	mm	2800
D	Max. Vertical Digging depth	mm	2310
E	Max. Digging reach	mm	4800
F	Max. Digging reached at ground level	mm	4680
G	Min. Swing radius of work equipment	mm	775
H	Max lifting height of the blade	mm	300
I	Max cutting depth of the blade	mm	320

Standard Configuration and Digging Force

Arm Length	mm	1300
Boom Length	mm	2090
Bucket capacity	m ³	0.065
Arm digging force	kN	14.8
Bucket digging force	kN	24

NOTICE

Optional and special attachments not supplied by CFG industrial Ltd., May be used on the Machinery only after approval and authorization by CFG industrial Ltd.

Operating Weight and Ground Specific Pressure

Track shoes width	mm	300
Operating weight	kg	2700(standard driver's shed)/2800(standard driver's cage)
Ground pressure	kPa	26/27

Disclaimer

This manual is used as the machine maintenance data, the recorded information including text, data, pictures or other items may be inconsistent with the actual products sold, this manual cannot be used as the basis of product style, the purchase of products shall be subject to the actual delivery. Products are subject to change without prior notice.

便签页

ATTACHMENTS AND OPTIONS



WARNING

Please read and make sure that you understand the SAFETY section before reading this section.

Safety First

When installing attachments or options to the machine, it is necessary to pay attention to safety. Please obey the following precautions strictly when selecting, installing, or using attachments or options.

Install only attachments or options authorized by CFG. CFG cannot accept any responsibility for any accident, damage, or failure caused by the use of attachments or options not authorized by CFG.



General considerations

- Accessories are powerful tools. To prevent serious injury or damage, use them correctly.
- Read through the attached instructions. Do not use attachments without fully understanding the instructions. If the instruction manual is lost, contact the manufacturer or attachment sales company for a new one.
- Install the necessary front cover on the machine as attached.
- Depending on the attachment, vibration noise will make it difficult for colleagues to communicate instructions. Before starting operation, assign a conductor and determine the signal to be used.
- Do not perform rotary operation with heavy loads on the attachment. Doing so on slopes is particularly dangerous.
- A machine with a crusher hammer has a heavier load on the front part of the work unit and is unstable compared to the one with a bucket. To avoid the risk of tipping, do not operate when the attachment is turned sideways.
- When accessories are installed, the range and center of rotation of the machine are different. The machine will move unexpectedly. Be sure to know the machine properly.
- Set up some security lines around the machine before operation to prevent people from entering. Do not operate the machine when there is a man near it.
- To prevent serious accidents caused by disoperation, do not put your foot on the pedal except when operating the pedal.

Precautions when removing or installing

When removing or installing the attachment or option, obey the following precautions, and take care to ensure safety during the operation.

- Carry out the removal and installation operation on a flat, firm ground surface.
- When the operation is carried out by two or more workers, choose the leader and follow his instructions.
- Use a crane when handling heavy objects (more than 25 kg (55 lb)). (The crane must be operated by a qualified operator.)
- Never go under a load raised by the crane.
- Do not carry out operations with the load kept raised by the crane. Always use a stand to prevent the load from falling.
- When removing a heavy part, consider the balance after it is removed. To prevent the machine from tipping over, set a support in position if necessary before removing the part.
- Before installing or after removing the attachment or option, set it in a stable condition to prevent it from falling over.

Notice

For details of the removal or installation operation, please consult your CFG distributor.

For details of disassemble and installation operations, contact the dealer.

Attachment Installation

! WARNING
 When long or heavy work equipment is installed, remember the following precautions.

- Before starting operations, move the machine to a safe place and carry out a test operation to make sure that you fully understand the movement, center of gravity, and working range of the machine.
- Do not swing the work equipment if the machine is at an angle. If the work equipment is swung with the machine at an angle, there is danger that the machine will tip over.
- Always maintain a safe distance from obstacles in the surrounding area when operating. If long work equipment is installed, the working range becomes larger.
- The swing overrun (the distance the work equipment moves before completely stopping after the swing brake is applied) will be greater. There is danger of hitting objects if the swing overrun is miscalculated, so allow extra space to the swing position when swinging.
- The hydraulic drift of the work equipment (the amount of the work equipment moves down under its own weight when it is stopped in a raised position) also becomes greater. Do not stop the work equipment in a raised position; always lower it to the ground.
- Do not swing, lower, or stop the work equipment suddenly. There is danger that the machine may tip over.
- Do not suddenly extend or retract the boom cylinder. The shock may cause the machine to tip over.

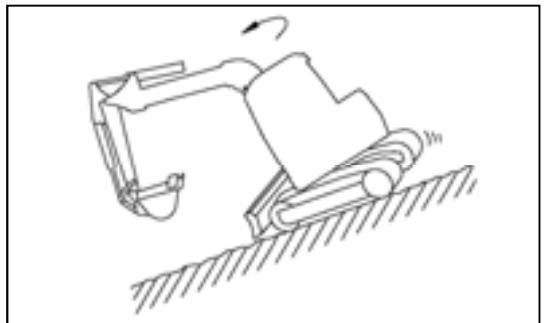
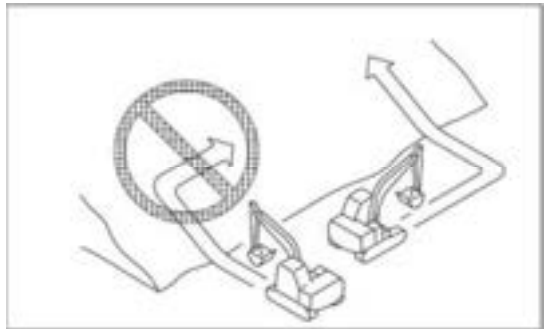
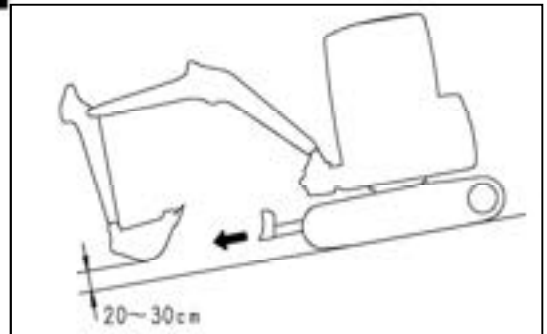

Recommended Attachment Operations

NOTICE

Select the optimum model of attachment for a hydraulic excavator on which it is to be mounted. Depending on machine models of hydraulic excavator, the kind of attachments or the model of specific attachments that can be mounted will vary. Hence, consult your CFG distributor for the selection of optimum attachments.

Hydraulic Breaker

Main Applications

- Crushed rock
- Demolition work
- Road construction

This attachment can be used for a wide range of applications including demolition of buildings, breaking up road surfaces or slag, tunnel work, rock crushing and breaking operations in quarries.

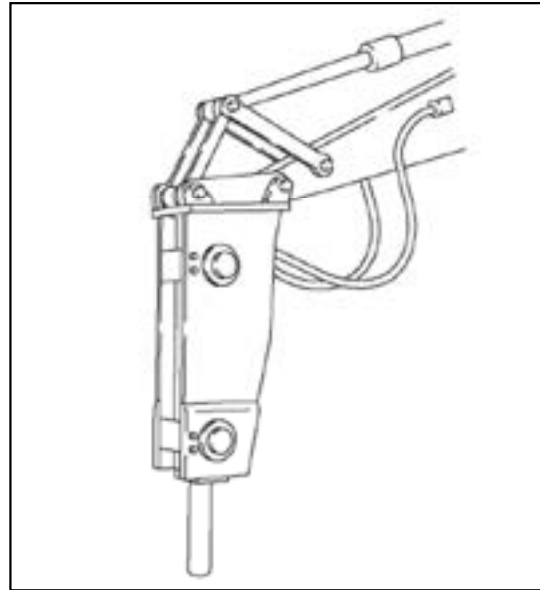

- Keep the chisel pushed perpendicularly against the impact surface when carrying out breaking operations.

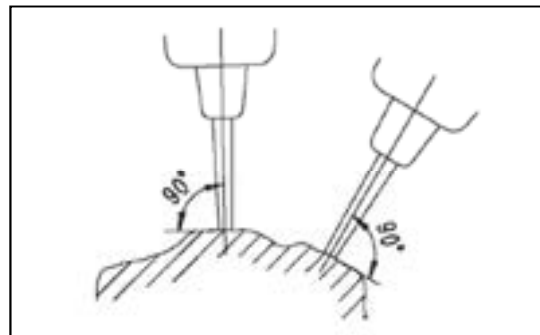

- When applying impact, push the chisel against the impact surface and operate so that the chassis rises approx. 5 cm (2 in) off the ground. Do not let the machine come further off the ground than this amount.

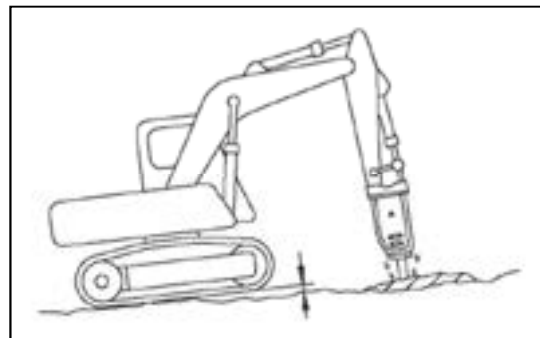

- When applying continuous impact to the same impact surface, if the chisel does not penetrate or break the surface within 1 minute, change the point of impact and carry out breaking operations closer to the edge.

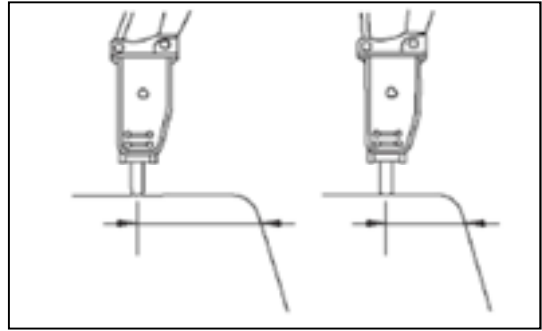

- The direction of penetration of the chisel and the direction of the breaker body will gradually move out of line with each other, always adjust the bucket cylinder to keep them aligned.

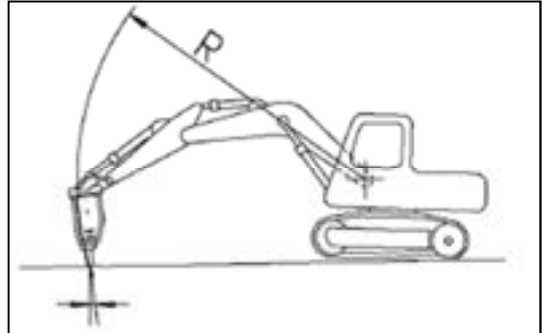

- Always keep the chisel pressed against the impact surface properly to prevent using the impact force when there is no resistance.

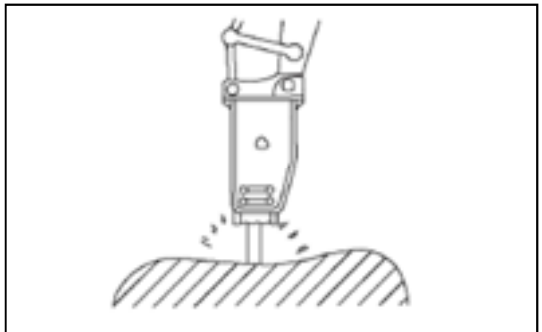

Prohibited Works

To ensure that the machine has a long life, and to ensure that operations are carried out in safety, do not operate the machine in any of the following ways.

- Do not operate all cylinders to the end of their strokes. Always leave approx. 5 cm (2 in) to spare.
- Using the mount to gather in pieces of rock



- Operations using the swing force

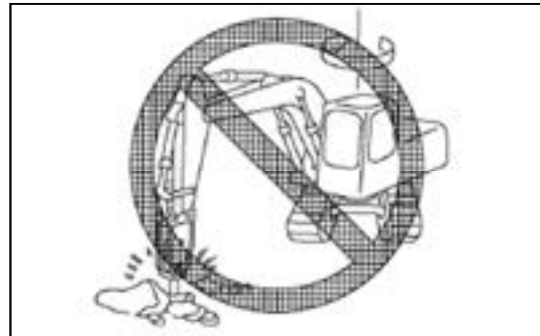

- Moving the chisel while carrying out impacting operations



- Holding the chisel horizontal or pointed up when carrying out impacting operations

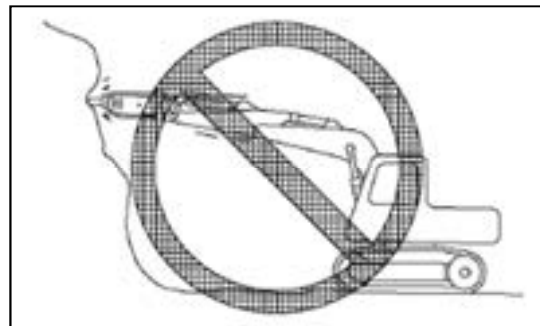

- Twisting the chisel when it has penetrated the rock



- Pecking operation

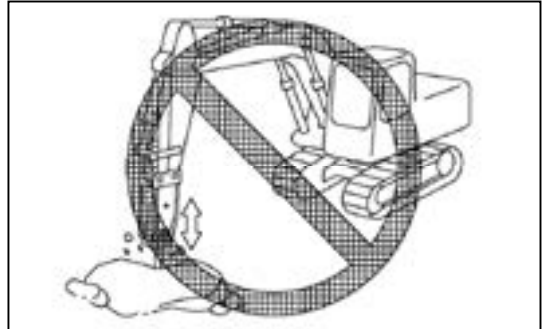

- Extending the bucket cylinder fully and thrusting to raise the machine off the ground

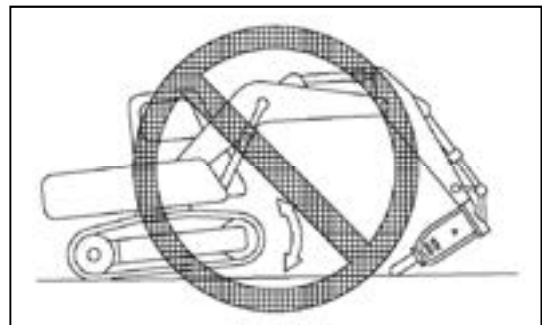

Supply Grease in the Correct Position

NOTICE

If the breaker is greased in an improper posture, it is filled with more grease than necessary. As a result, soil and sand will enter the hydraulic circuit and can damage the hydraulic components, while the breaker is in use. Therefore, be sure to grease the breaker, holding it in the right posture.

Other specific steps refer to "Hydraulic Breaker Operation and Maintenance Manual"

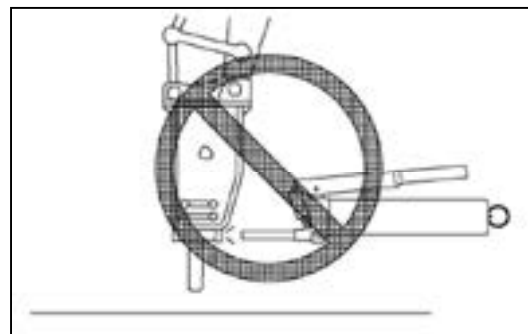
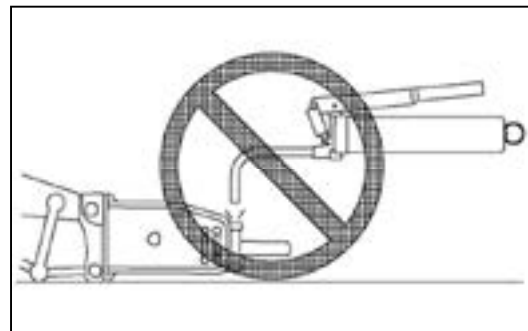
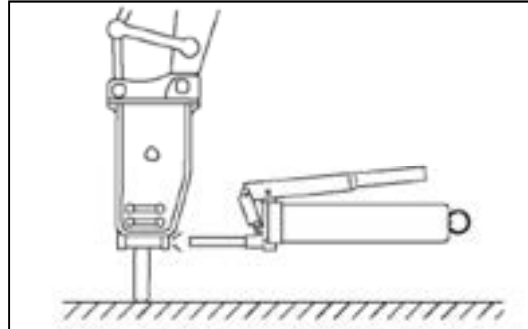

便签页

便签页



8. MANUFACTURER INFORMATION

Company: CFG INDUSTRIAL LTD.

Trade mark: 

Add: 6200 S Oak Park Ave, Chicago, Illinois 96938, United States

Sales hotline: 773-927-8098; **Servicehotline:** 773-927-8098

Maintenance point: Our office in various provinces and cities of China and USA